

SY 220 & SY 225 ORA Mains Driver Integrated System Installation and Operating Instructions

Congratulations! You have purchased a LUMISHORE advanced technology underwater light. Every care has been taken to ensure your LUMISHORE lights and drivers arrives in perfect condition, so please enjoy the ultimate experience in underwater lighting.

LUMISHORE high intensity underwater lights are designed for those owners who prefer the integrity of a Weld-in installation in a light that employs the most powerful, efficient and cost effective underwater LED lighting on the market today. The LUMISHORE Weld-in lighting system is suitable for many sizes and types of watercraft, including Sports Boats, Cruisers, Yachts and Super Yachts. LUMISHORE Weld-in LED lights come with a compact electronic driver module to ensure trouble free operation for years to come.

Please read the following pages before attempting installation to ensure complete understanding of the LUMISHORE LED lights.

BEFORE YOU START

- **High Intensity LED light – Do not stare into the LED module at close proximity.**
- Always ensure that the vessel's power source is disconnected or isolated prior to installation
- A qualified professional should carry out both the electrical and mechanical installation. If in doubt please contact LUMISHORE. refer to product support section
- The Driver supplies voltage and current to the Underwater lights. **Under no circumstances should the light cable be cut and connected directly to voltage**
- Always use a suitable fuse or circuit breaker to protect the complete system. Each light to be individually fused.
- The light should be installed 6" - 10" (150-250mm) below the minimum load waterline.
- For best results install the lights between 2.5ft (0.8m) and 6.5ft (2m) apart.
- Never try to install or remove light with the vessel in the water.
- Lights should not be exposed to any temperatures in excess of 150°F (65°C). For example, next to hot engine components or where exhaust emissions could be expelled onto the light while underwater

SUPPLIED PARTS

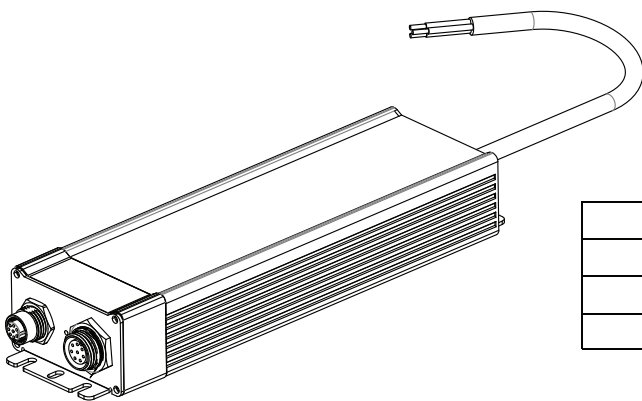

SY 220 & SY 225 Mains Driver Part Numbers

Product	No
SY 220 & SY 225 ORA WHITE	39-0166
SY 220 ORA WARM WHITE	39-0172
SY 225 ORA BLUE	39-0249

TYPICAL INSTALLATION

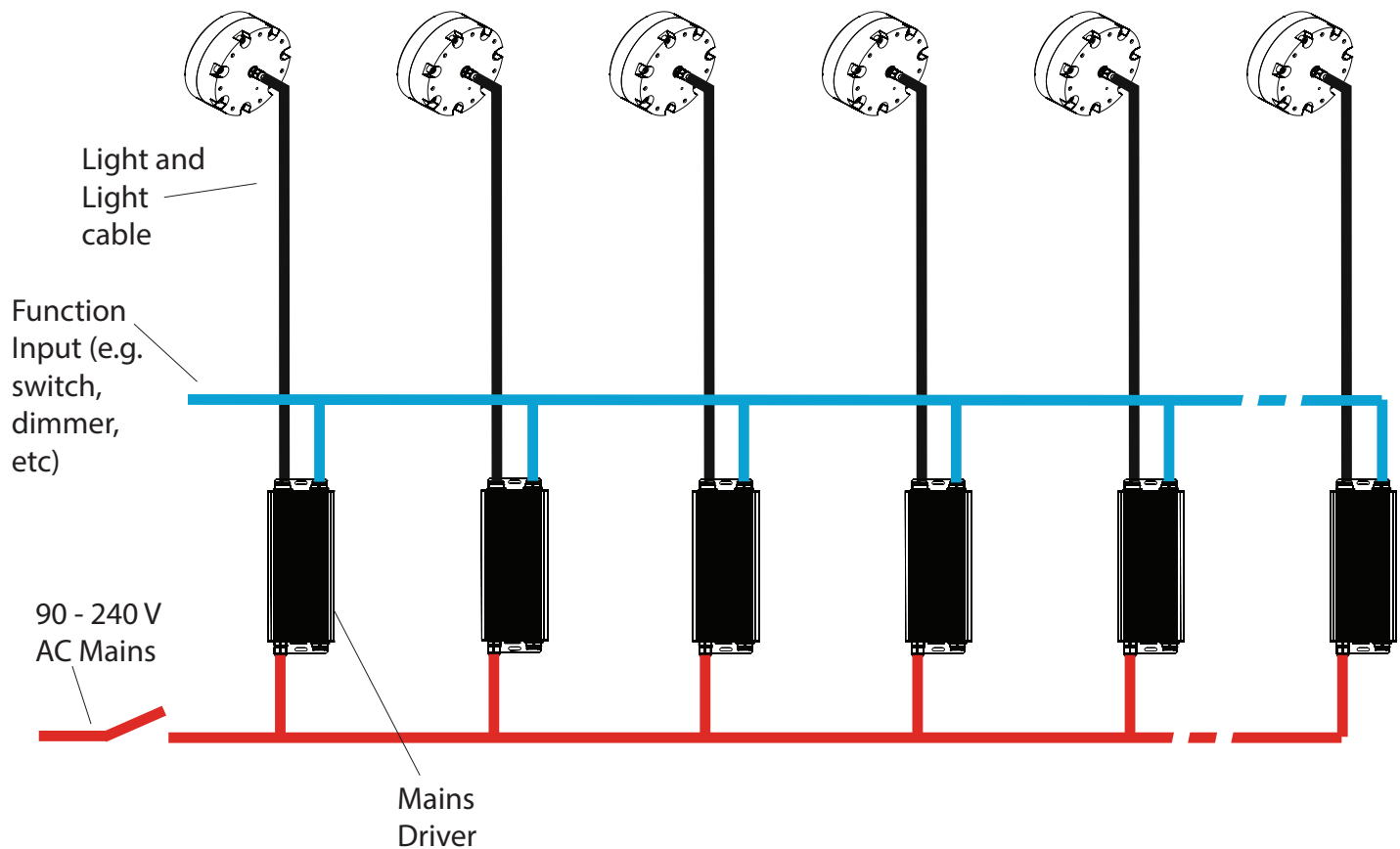

The SY 220 & SY 225 ORA Mains drivers can be configured to have the following functions:

- On / Off
- Strobe (via external input to the driver)
- Dimming (via external input to the driver)

Note: Switching the lights On / Off can be done by just switching power on / off to the driver, with no need for the function cable to be connected. For further information on how to switch the lights on / off via the function port see page 4.

For details on the light installation please refer to the light installation instructions.

INSTALLING THE MAINS DRIVER

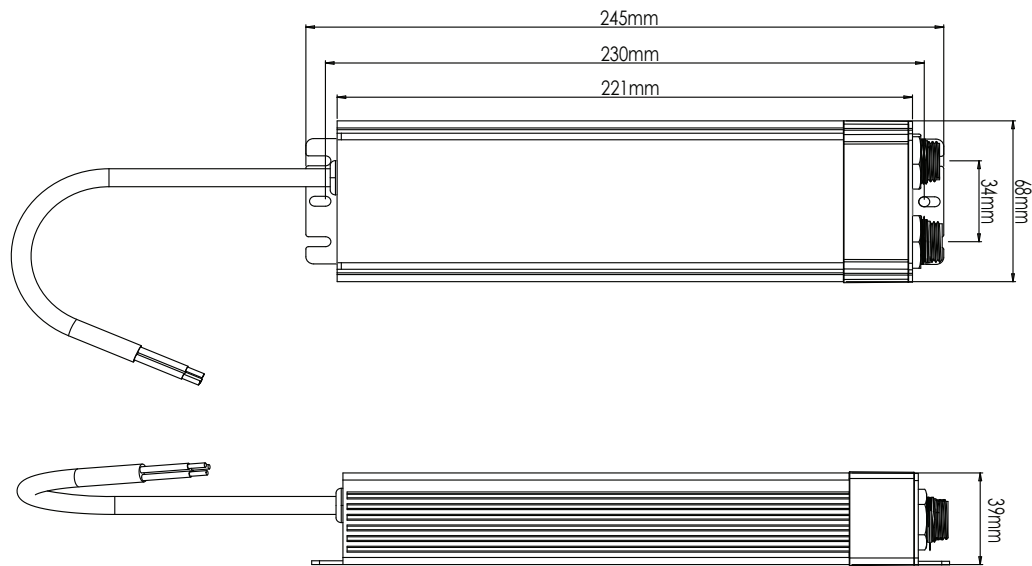

Input Voltage Range: 90-240VAC (50/60Hz)

Maximum Input Current: 1.2 Amp

Input Wiring:

Brown Wire : LIVE

Blue Wire : NEUTRAL

Green/Yellow: EARTH

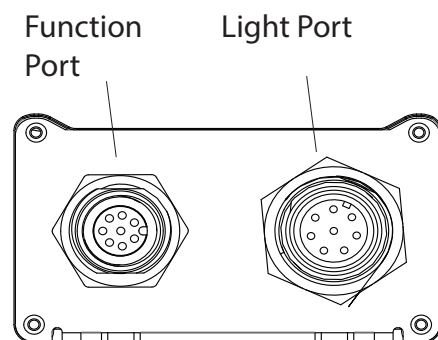

When Installing the drivers these instructions shall be followed:

- The driver should be mounted in an accessible area within reach of the light cable length supplied. Take care to plan the cable route to the light
- The driver should be mounted to a flat, insulating surface using the two mounting holes at either end
- The input voltage cable used should be a suitable marine approved mains cable

For details on the light installation please refer to the light installation instructions.

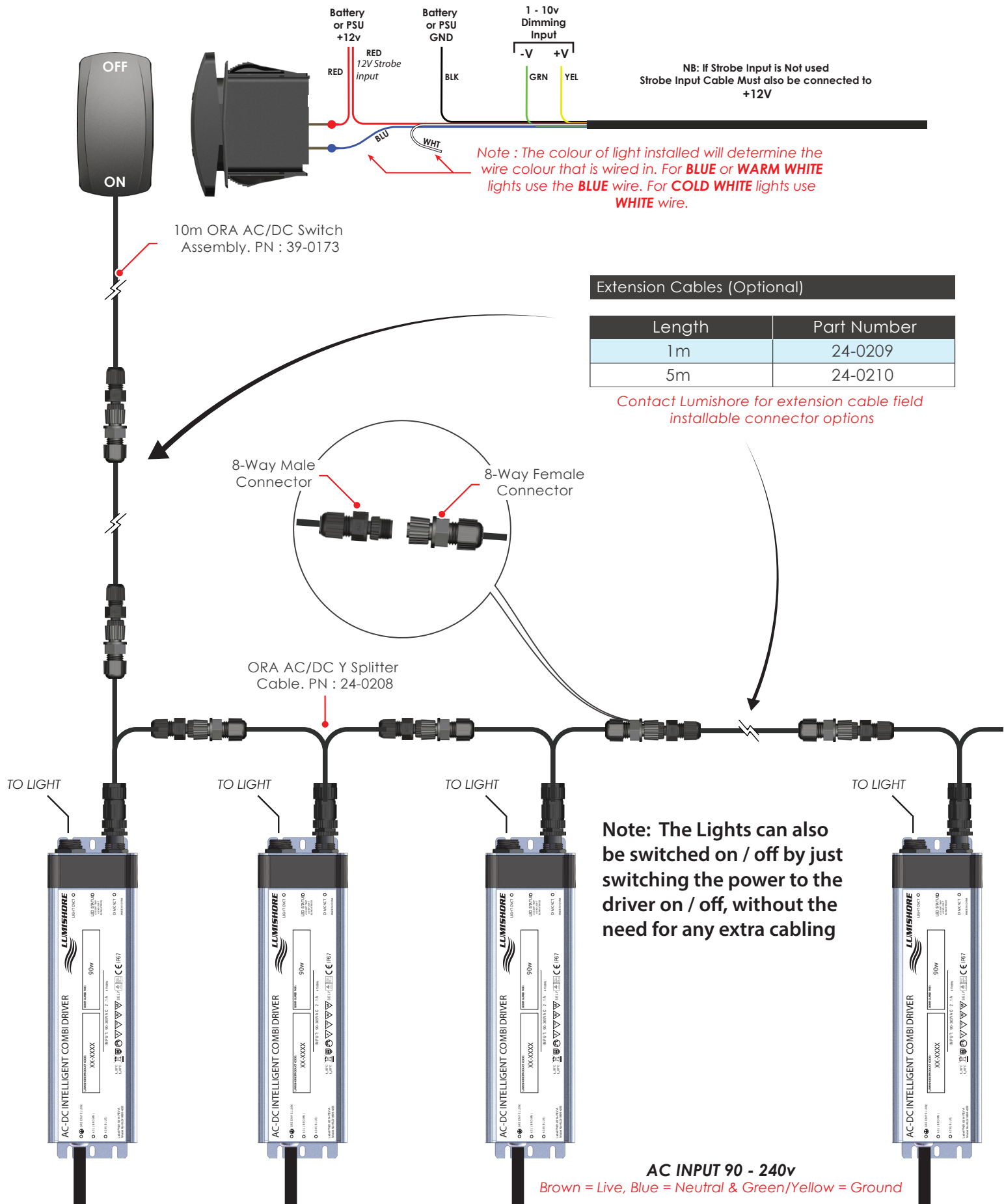

How to Add 3rd party 1-10V for dimming control

The Lights can be dimmed using a 3rd party 1-10volt dimming module. Connect the 1-10volts between the green and yellow wires of the Switch assembly. Note: The dimming module must be a Current Sink Module with a capacity >10mA **per light** - do not use a current source module or adjustable power supply!

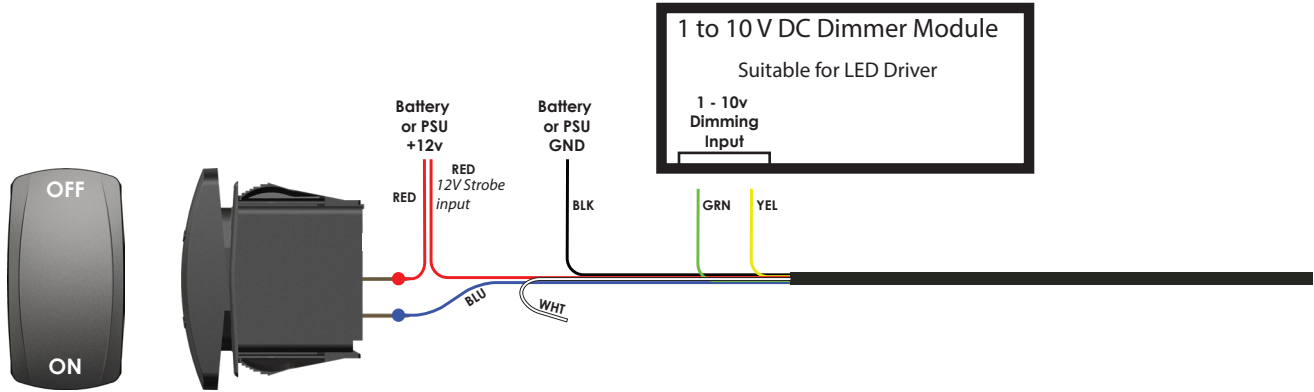

How to connect a STROBE FUNCTION

The lights can be strobed using a 12V Switching Signal Generator. When the signal generator is switched ON the lights will come ON, when the signal is switched OFF, the lights will switch OFF.

Remove the strobe input cable from the switch assembly and connect to a 12Volt Strobe / signal generator. Note when strobe function is not in use the strobe input should be kept to +12volts

Note: In this mode, when the lights are initially switched ON they will light up and wait for a signal. Once they receive this signal they will respond (NO signal = OFF, Signal = ON). This will remain the case until the lights are switched off and on again using the switch.

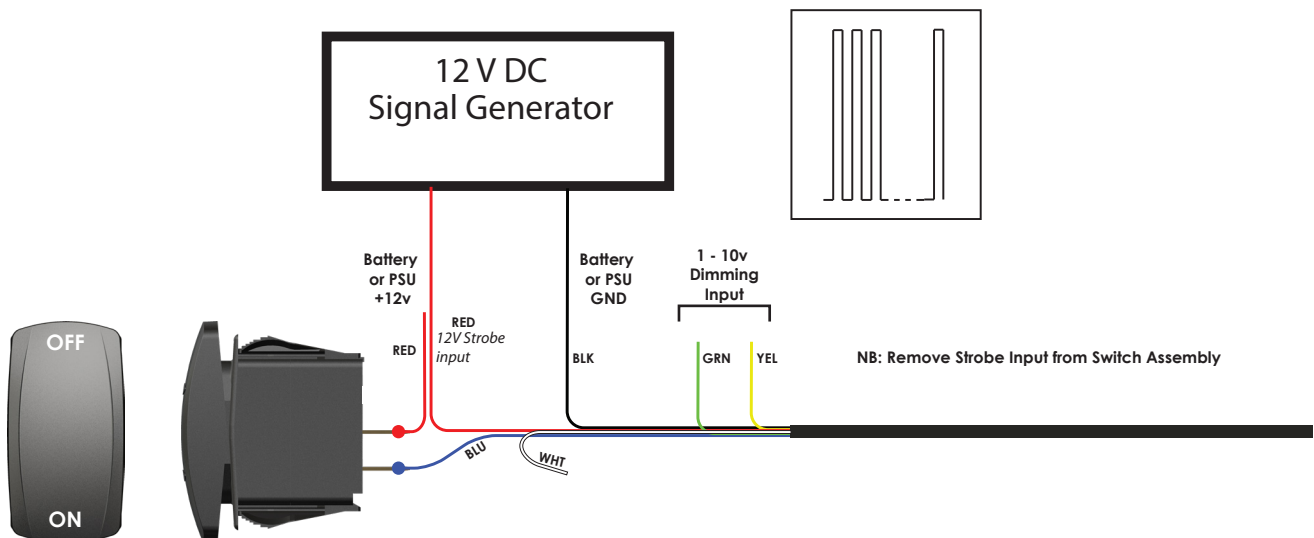

TESTING THE LIGHTS

The underwater lighting system should always be tested before the boat goes back in the water. Check that each light comes on, and all lights change in sequence as per the system operation section above. See the problem solving guide for advice on resolving any issues.

WARRANTY

LUMISHORE Ltd warrants the lighting system to be free from defects in workmanship for a period of three years, starting from the date of original purchase. Should your lighting system have a problem during this period, please contact your dealer as soon as you become aware of the defect.

Misuse, abuse, improper installation, neglect, improper shipping, damage caused by disasters (e.g. fire, flood and lightning), installation by unqualified personnel, unauthorized repair or modification will void this warranty. For the avoidance of confusion and doubt, non compliance with all installation, maintenance and operating instructions in this document constitute non conformance with warranty terms.

Full warranty details are available at www.lumishore.com.

TROUBLESHOOTING

In the event of one or more of the lights not lighting up then check the LED status on the driver. The LED will either be continually ON (healthy), OFF (no power to driver) or flashing. Please refer to the table below for what the number of flashes means and what action to take..

LED Status	Meaning	Action to take / Things to check
No LED light on driver	No power to driver	Check fuse / breaker Check connections Check voltage at input to driver connections
Solid LED	Power On	Driver is receiving voltage and operating properly Check the switch is operating correctly
Flashing 5 times	Driver cannot detect light	Check power connection to light Check the connection on the back of the light (if present)

In the event of an issue then:

1. Check the operation of the light and driver with only that light and driver powered
2. If the light is still not operational then swap the driver with the flashing LED with a driver which is known to be working and re-test the light
3. Test the driver with a known good light
4. This will determine if the issue is with the light or the driver
5. Record the serial numbers of both the light and the driver and contact your local dealer



If a light does not switch on, or function normally it should be disconnected from the power source