

LUX Strip Light driver regulated with built-in voltage stabilizer Installation Guide

Please read the following pages before attempting installation to ensure complete understanding of the LUMISHORE LUX Strip Light driver regulated with built-in voltage stabilizer



Before you start...

- Always ensure that the vessel's power source and battery are disconnected or isolated prior to installation.
- A qualified professional should carry out both the electrical and mechanical installation.
- The Strip light driver should be mounted on a flat surface and in a cool, dry, well ventilated location.
- Each strip light driver should be individually fused and/or connected to a suitable circuit breaker.
- The LUX Strip light Driver is designed to work with Lumishore LUX strip lighting products ONLY, do not use with other Strip light brands, this will invalidate the warranty.

The LUX Strip Light Driver Regulated with built in voltage stabilizer is suitable for both 12V and 24V vessels. It has built in circuitry to allow it to operate over a range of 10-31volts input and will ensure a regulated and stabilized output of 24volts.

Basic Dimensions:

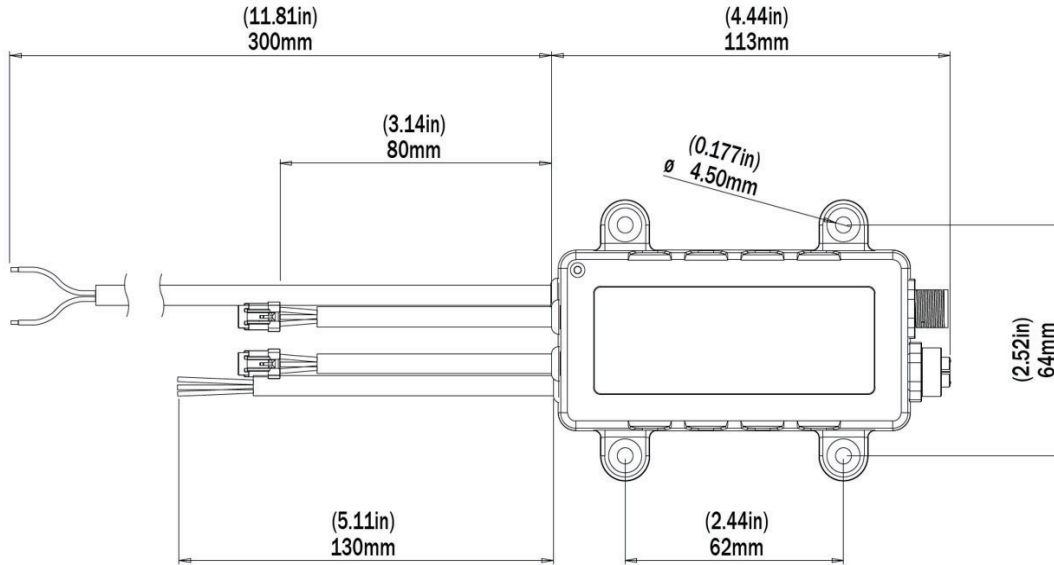

Electrical specification:

- Input = 10.5 to 31 Volt
- Output = 24Volt (stabilized)
- Typical current draw = 5.6@12V, 2.8@24V
- Max power = 68watts
- Max strip light length = 10 Meters (2 x 5 meter)

Fuse rating (Note: Each Strip light driver should be connected via an in-line fuse or circuit breaker)

Input Voltage	Fuse Rating
12v	7.5 Amp
24v	4 Amp

Input & Output connections:

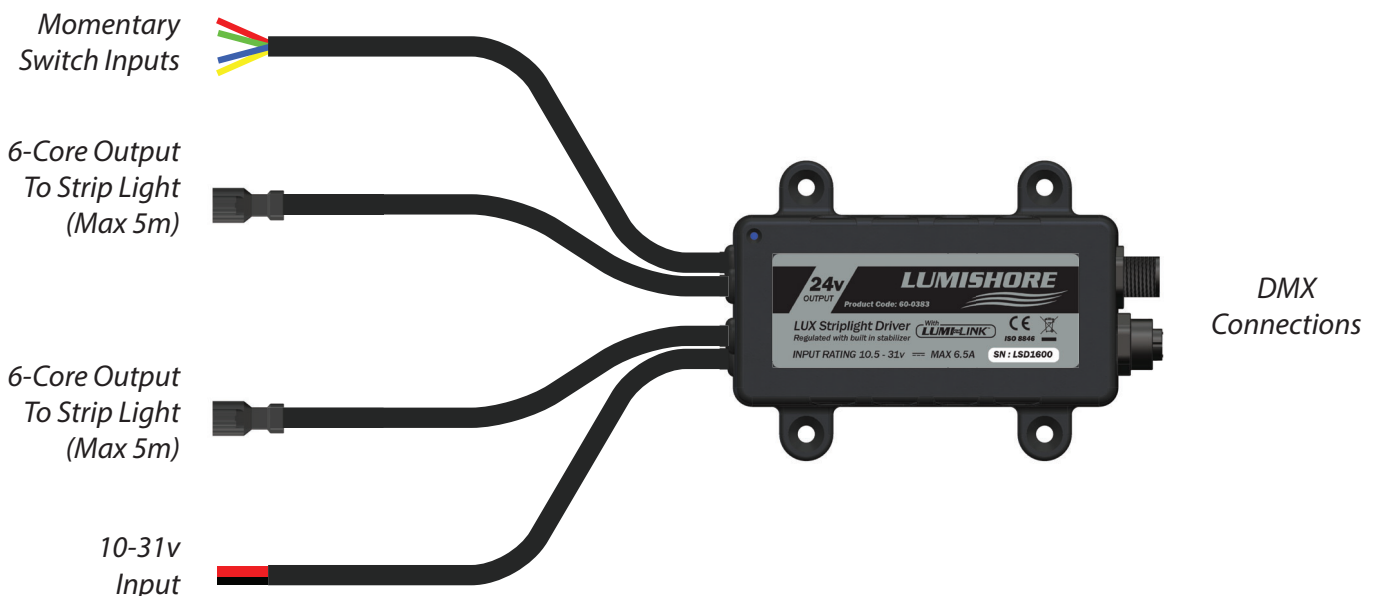

Installation Diagram (Switch Only Operation):

The LUX Strip light driver can be installed as a stand alone strip light driver and operated with momentary switches

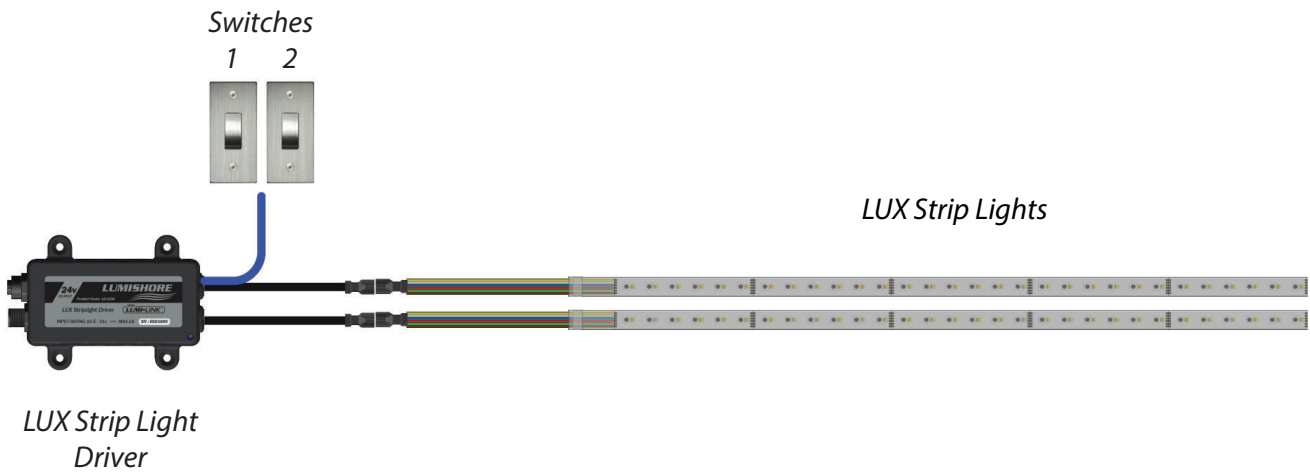

A choice of different switch options are available.....

Option 1

- Switch 1 = On / Off (Hold to dim)
- Switch 2** = Cold White / Neutral White / Warm White

Option 2

- Switch 1 = On / Off (Hold to dim)
- Switch 2** = Cold white /Neutral White/Warm White/Red/Blue/Green/Magenta/Cyan

**Switch 2 is optional

The wiring diagram to connect the switches options above are shown on the following pages all unused switch wire inputs should be isolated.

Switch Wiring Diagram - On/off and Preset white colors

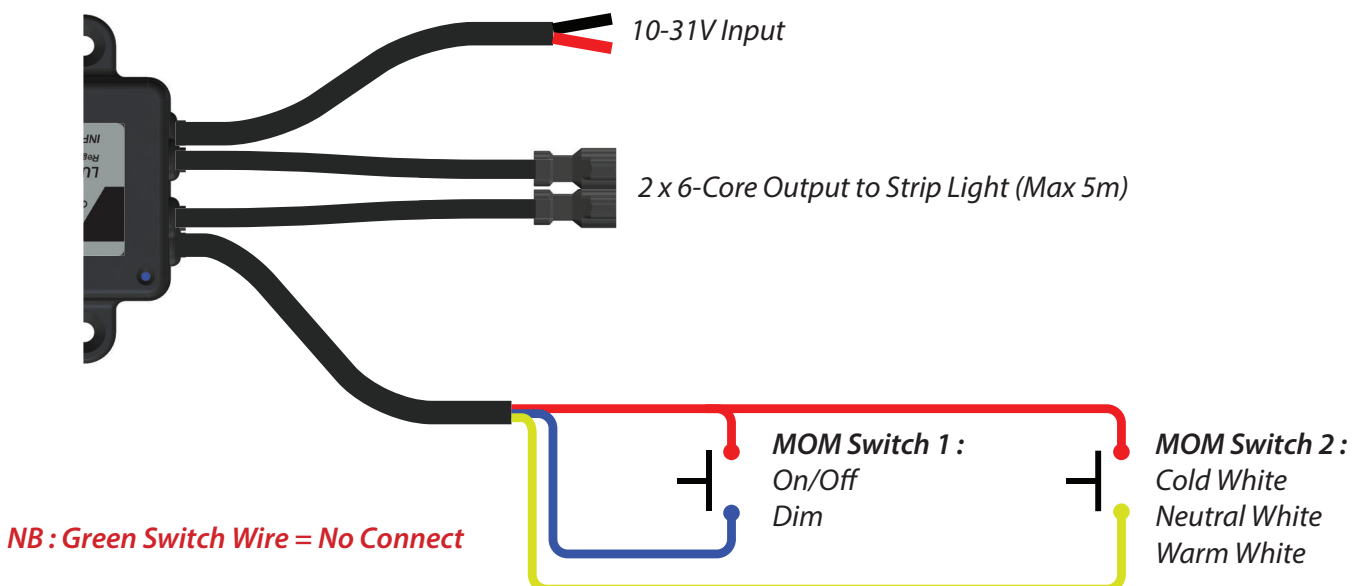

Switch Wiring Diagram - On/off, Preset white colors and RGB

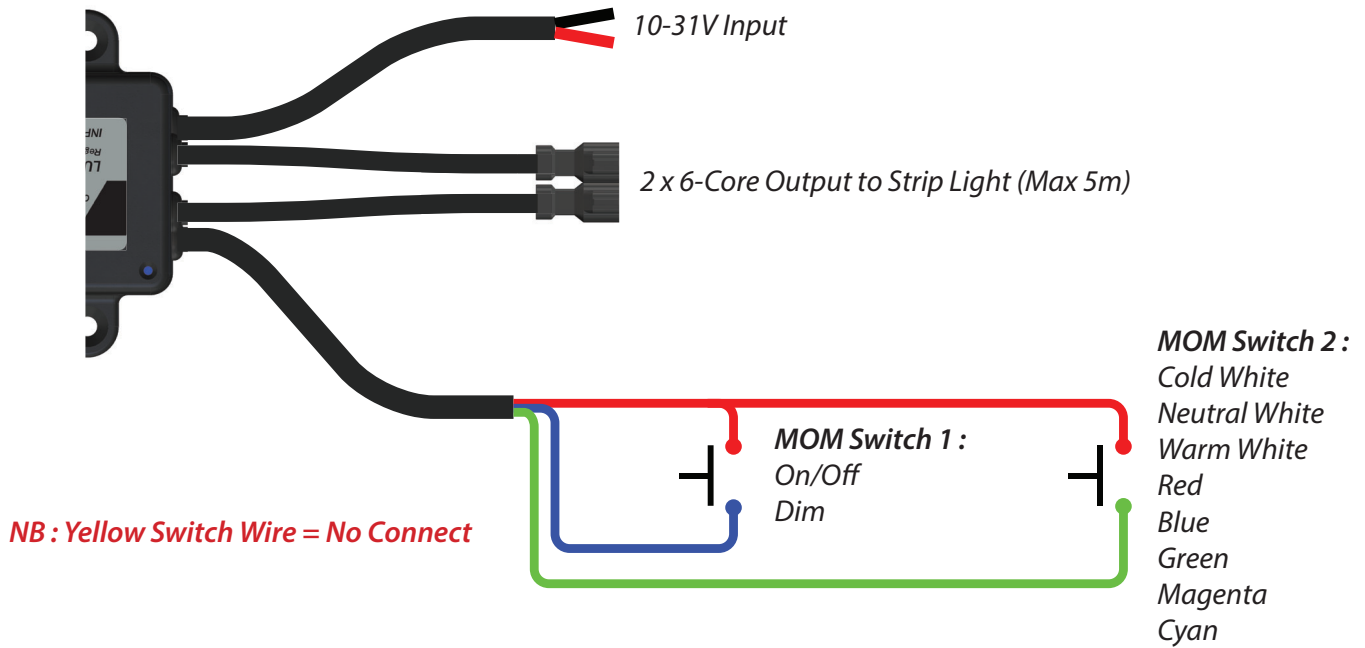

Installation Diagram (Switch control and EOS-LUX Command Center)

The LUX strip light driver can be used in conjunction with the EOS-LUX Command Center and other Lumishore LUX or EOS lighting products to offer complete vessel lighting control from the vessels multifunction display, EOS-LUX Display or Smart device. Each LUX module can also be controlled from independent momentary switches mounted in the room or dash board. When pressed, the switch removes control from the EOS-LUX command center and offers independent On/off control, dimming or preset color selection. To let the EOS-LUX command center regain control the associate zone should be powered off and on again at the MFD, smart device or EOS-LUX display.

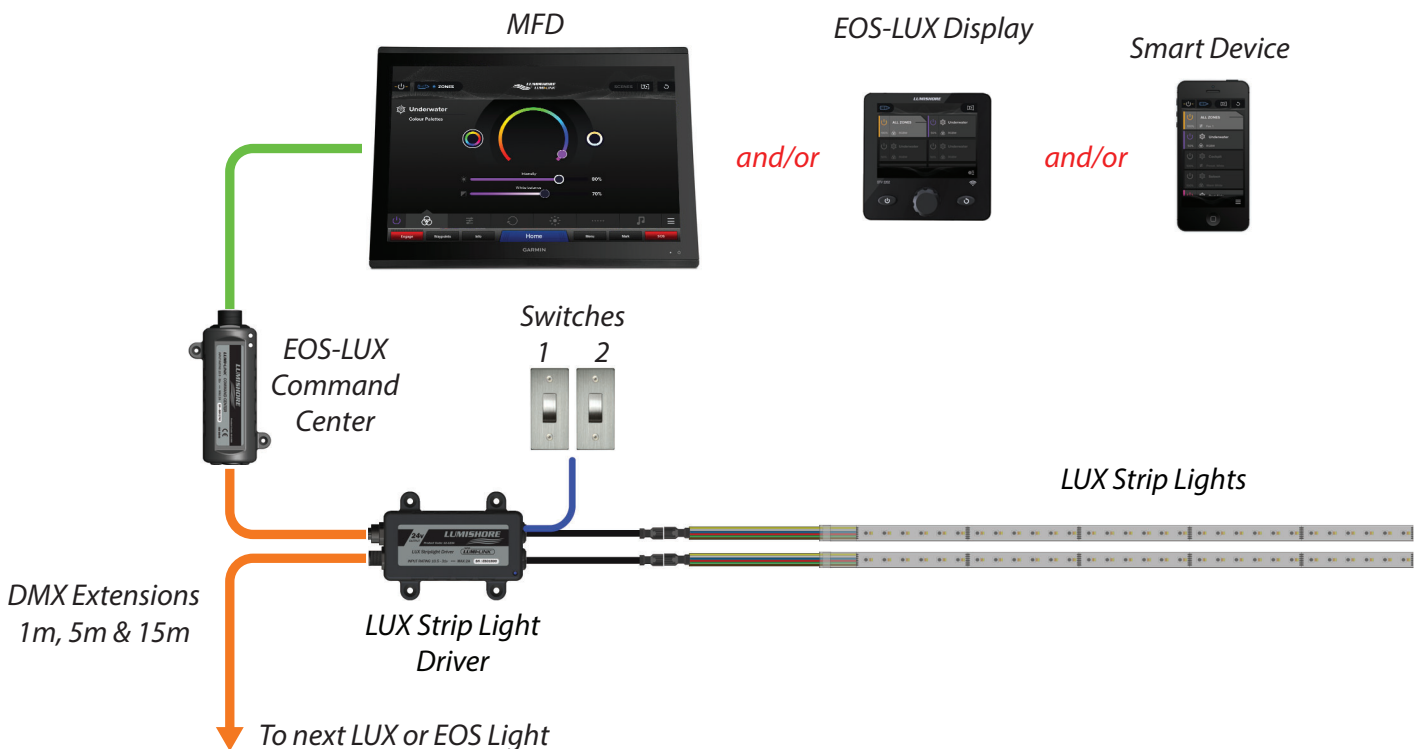

LUX SL/SNL Power Extension Cable (6 core between Driver and Strip Light)

The cable between strip light and driver can be extended using the premade 6 core extension cables. **Note: Multiple cable extensions can be joined together but the overall extension length should not exceed 15m.**

6-Core Extension Cables (Max 15m)



Length	Part Number
LUX SL/SNL Power Extension Cable - 1m	60-0385
LUX SL/SNL Power Extension Cable - 2m	60-0386
LUX SL/SNL Power Extension Cable - 3m	60-0387
LUX SL/SNL Power Extension Cable - 4m	60-0388
LUX SL/SNL Power Extension Cable - 5m	60-0389

Connecting more than 2 strip lights to The LUX strip light driver

Multiple Striplights can be connected to the striplight driver using Lumishore Lux 6 core 2 way or 3way splitters.

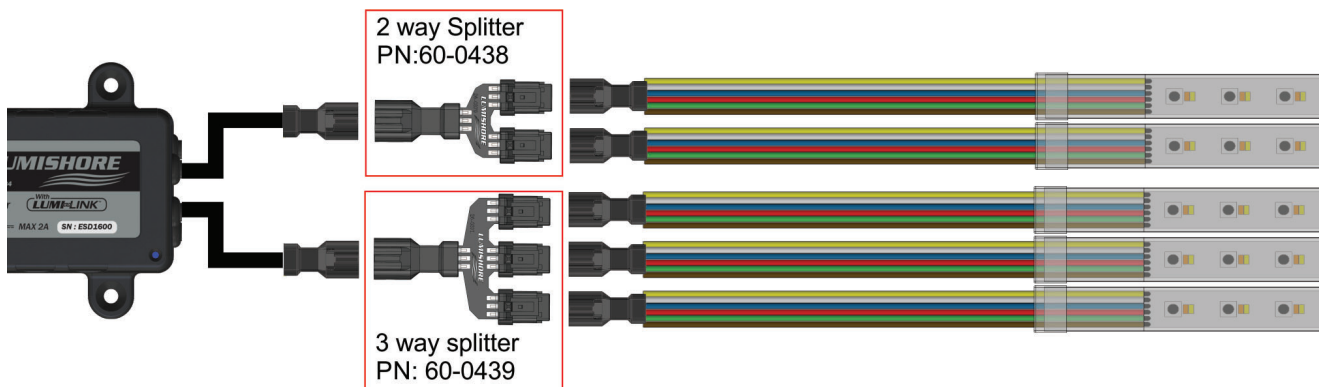

Status LED flash sequence



LED Status	LED Description	Module Status
	Solid On	Power OK
	Quick Blink	Data Received (Lumi-Link)
	Single Blink	Switch Input 1 Received
	Two Blinks	Switch Input 2 Received
	Three Blinks	Switch Input 3 Received

Warranty

LUMISHORE Ltd warrants its lighting systems and associated lights and accessories to be free from defects in workmanship for a period of three years, starting from the date of original purchase. Should your lighting system have a problem during this period, please contact your dealer, boat manufacturer or broker as soon as you become aware of the defect.

Misuse, abuse, improper installation, neglect, improper shipping, damage caused by disasters (e.g. fire, flood, storm and lightning), installation by unqualified personnel, unauthorized repair or modification or non-approved installations will void this warranty. For the avoidance of confusion and doubt, non compliance with all installation guidelines, maintenance and operating instructions in this document constitute non conformance with warranty terms.

Full warranty details including exclusions are available at www.Lumishore.com.

The LUX Strip light Driver is designed to work with Lumishore LUX strip lighting products ONLY, do not use with other Strip light brands, this will invalidate the warranty.