

TIX 404

Lumishore EOS Full Colour Change light Installation and Operating Guide

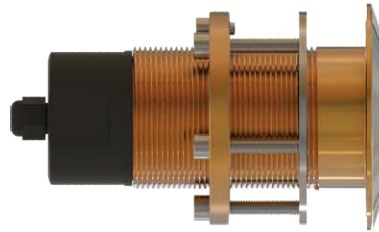

Congratulations! You have purchased a LUMISHORE advanced technology underwater light. Every care has been taken to ensure your Thru-Hull light arrives in perfect condition, so please enjoy the ultimate experience in underwater lighting.

LUMISHORE Thru-Hull high intensity lights are designed for those owners who prefer the integrity of a thru-hull installation in a light that employs the most powerful, efficient and cost effective underwater LED lighting on the market today. The LUMISHORE Thru-Hull is suitable for many sizes and types of watercraft, including Sports Boats, Cruisers, Yachts and Super Yachts.

Please read the following pages before attempting installation to ensure complete understanding of the LUMISHORE LED lights.

BEFORE YOU START

- **High Intensity LED light – Do not stare into the LED module at close proximity.**
- Always ensure that the vessel's power source and battery are disconnected or isolated prior to installation
- A qualified professional should carry out both the electrical and mechanical installation. If in doubt please contact LUMISHORE;
- Always use a suitable fuse or circuit breaker to protect the complete system. Each light to be individually fused.
- The Thru-Hull maybe installed into GRP (Glass Reinforced Plastic or Fibreglass) and wooden hulls.
- For metal hull or carbon fibre installations an isolation kit will be required.
- The light should be installed 6" - 10" (150-250mm) below the minimum load waterline.
- For best results install the lights between 2.5ft (0.8m) and 6.5ft (2m) apart.
- Never try to install or remove light with the vessel in the water.
- Lights should not be exposed to any temperatures in excess of 150°F (65°C). For example, next to hot engine components or where exhaust emissions could be expelled onto the light while underwater.
- Do not over tighten the retaining bolts. A force of **3Nm** on each bolt should not be exceeded.
- All LUMISHORE products should have a bonding to the DC system via bonding strap for galvanic protection.
- Choose a location - The light must be installed onto a flat (not curved) surface. Mount on transom or side hull only.

Note: For detailed installation instructions please refer to the installation manual that came with your controller / command center

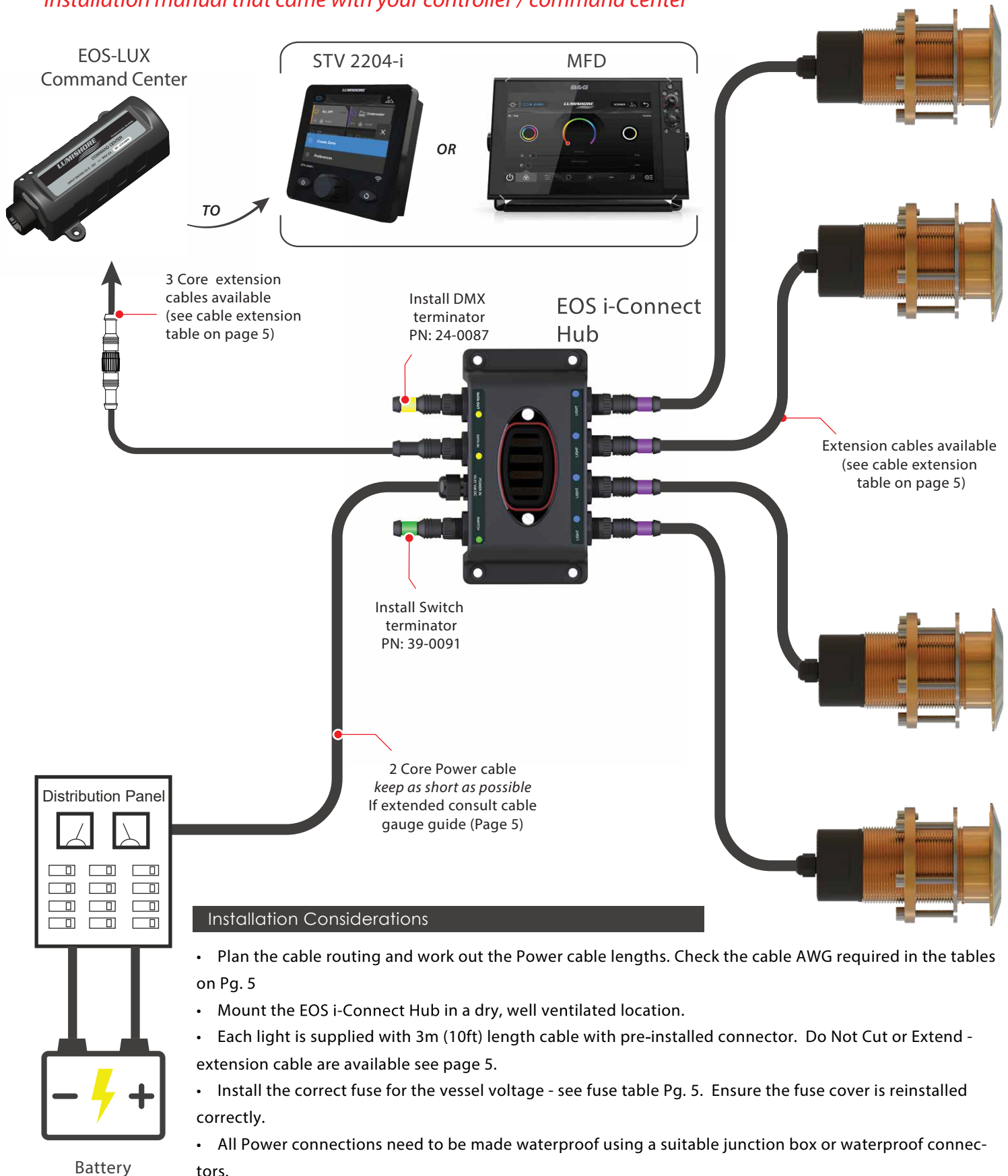

Installation Considerations

- Plan the cable routing and work out the Power cable lengths. Check the cable AWG required in the tables on Pg. 5
- Mount the EOS i-Connect Hub in a dry, well ventilated location.
- Each light is supplied with 3m (10ft) length cable with pre-installed connector. Do Not Cut or Extend - extension cable are available see page 5.
- Install the correct fuse for the vessel voltage - see fuse table Pg. 5. Ensure the fuse cover is reinstalled correctly.
- All Power connections need to be made waterproof using a suitable junction box or waterproof connectors.
- Ensure any unused ports on the Lumi-hub have the waterproof caps installed.
- All pre installed connectors are keyed - do not force and ensure they are aligned correctly.

Adding Extra Lights and Hubs

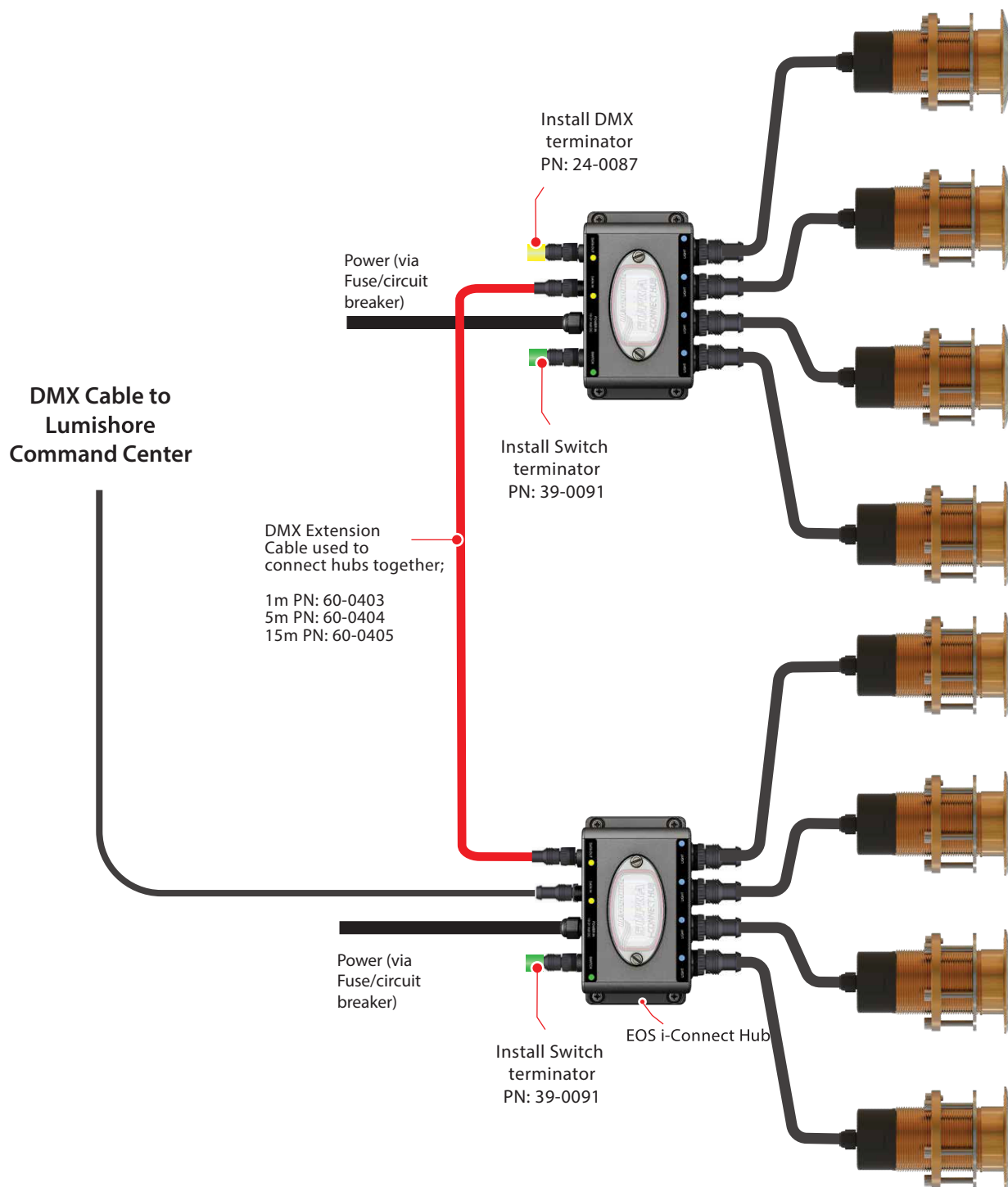

Note:

To add extra hubs simply provide power, fit the Switch Terminator and daisy chain together using the DMX Data in / Data out connections. Ensure the final hub in the chain has the DMX terminator is fitted to the Data Out port.

The tables below give the **minimum** cable gauge required depending on the supply voltage, and distance from the power source to the Lumi-Hub. Please ensure that the correct cable gauge is used in the installation

2 Core Power Cable Extension

Voltage	Length of extension cable from Hub to Battery				
	10ft / 3m	20ft / 6m	30ft / 9m	40ft / 12m	50ft / 15m
12V	8 Awg	6 Awg	6 Awg	4 Awg	4 Awg
24V	16 Awg	14 Awg	12 Awg	10 Awg	8 Awg

AWG to Metric conversion table

AWG Size	Cross sectional Area	Cable diameter
18	1mm ²	0.8mm
16	1.3mm ²	1.3mm
14	2.0mm ²	1.6mm
12	3.3mm ²	2.0mm
10	5.2mm ²	2.5mm
8	8.3mm ²	3.2mm
6	13mm ²	4.1mm
4	20mm ²	5.1mm

5 Core Cable extensions from Lumi-Hub to Light

Supply Voltage	Total Cable Distance from hub to light	Part Number
12V DC / 24V DC	6m (Light cable plus 1 extension cable)	60-0407

Fuse Selection

Light Type	12V DC	24V DC
TIX404 EOS	7.5A	4A

3 Core Cable extensions from EOS i-Connect Hub to EOS i-Connect Hub or EOS i-Connect Hub to EOS Controller

NOTE: Do Not Cut and Splice DMX cables

Length	Part Number
1m	60-0403
5m	60-0404
15m	60-0405

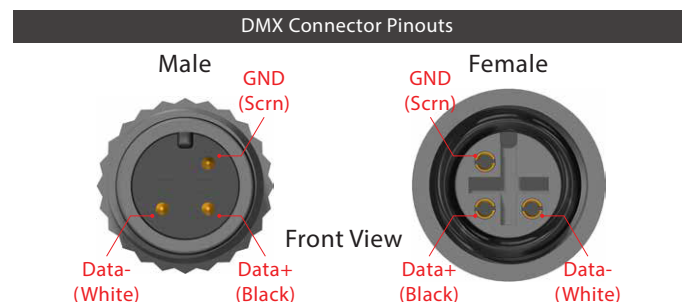



DO NOT attempt to unscrew or remove cartridge from light body. Doing so will invalidate warranty and potentially damage the LED module.

Bonding Attention: Failure to bond the lights properly and maintain the appropriate protection will invalidate the LUMISHORE warranty.

LUMISHORE lights should be connected to the vessel's DC Bonding system to ensure protection from electrolytic / galvanic corrosion. All bonding connections should be fully checked prior to returning the vessel to the water. LUMISHORE lights have integrated circuitry to protect lights from external issues, but these are dependent upon correct bonding.

Installation into a wood, metal or carbon fibre hull requires an isolation sleeve kit. In this case **DO NOT** Bond lights.

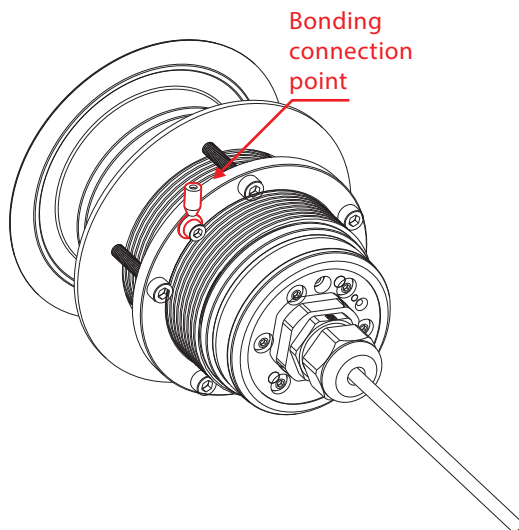

Metal Hull - isolation Sleeve

Isolation Sleeve kit

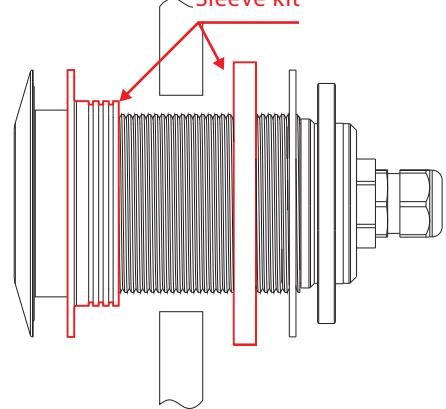

Model	Part Number
TIX404	60-0558

Installation Considerations

- Location - Positioning will be dependent on both external and internal obstacles; consideration should be given to installation wiring and internal access within the vessel. Ideally the light modules should be installed 6" to 10" (150-250mm) below the water line and spaced between 2.5ft to 6.5ft (0.8-2m) apart.
- Select a flat surface, make sure that both the internal and external surfaces of the hull are even and parallel. It may be necessary to sand or grind the surface.
- A hole will be drilled to allow the Thru-Hull light to be inserted. Care must be taken to ensure there is unrestricted access inside the hull
- The light is temperature sensitive and must not be located close to the exhaust or other heat sources.
- If multiple lights are installed, each light should be evenly spaced to ensure the best water illumination. The number of lights and the spacing on your vessel will depend on a few factors: vessel size, location of lights and water clarity.

Tools Required



5mm Allen Wrench

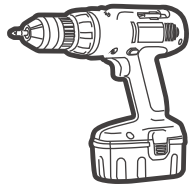

Drill/Driver

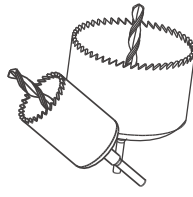

Hole-saw



Marine Sealant
(Use only 3M 4200)



Rags for clean-up

1. Measure the position of the lights on a flat part of the hull. Mark carefully, and double-check for internal obstacles.
2. Check the required hole size against the table below. Drill a perpendicular hole through the hull using an appropriate cutter for the hull material.

Model	Hole Size	Hole Size W/Delrin Sleeve
TIX 404	57mm (2.25")	64mm (2.5")

3. The exposed inner hull surface must be properly sealed to prevent water intrusion into the hull before the Thru-Hull is secured in place.
4. Before inserting the Thru-Hull ensure that the hull surface is free from dirt and grease and remove any existing anti-foul from the hull surface.



Note: Do not use an alcohol-based solvent as this may have an adverse effect on the sealant

5. Using an approved adhesive (3M 4200 Marine (recommended) or similar), apply liberally a continuous bead of sealant around the entire circumference of the sealant groove, on the base of the stem and on the shaft of the Thru-Hull.
6. Feed the connector and cable through the hole in the hull avoiding any strain on the cable. Gently insert the stem of the Thru-Hull light assembly through the hole in the hull.
7. Apply even pressure with a slight circular motion until the Thru-Hull is flush with the hull surface.
8. From inside the vessel, feed the supplied washer down the shaft of the Thru-Hull fitting. Screw the locking nut in place and tighten the retaining bolts so that they are hand tight (less than 1Nm) - **Do not tighten fully at this stage, excess pressure will push all of the sealant out.**
9. Remove excess sealant that is squeezed from behind the light with a rag.
10. Allow the sealant to cure according to the sealant manufacturer's instructions. Once fully cured, using a 5mm Allen wrench, re-tighten each retaining bolt (force less than **3Nm**). **Care should be taken not to exceed this force as damage to the light module or hull of the vessel may occur.**
11. Attach the vessel's bonding protection to the bonding bolt on the locking ring.

Testing the Lights



The underwater lighting system should always be tested before the boat goes back in the water. Check that each light comes on, and all lights change in sequence as per the system operation section above. See the problem solving guide for advice on resolving any issues.

Once the boat is back in the water, check for any water ingress on the installed lights. Any ingress should be dealt with immediately. The lights should be checked several times over the first 24-hours and periodically after that to ensure installation is satisfactory.

Maintenance and Cleaning

The locking nut and retaining bolts should be inspected on a regular basis to ensure they are kept tight. LUMISHORE recommends general inspection of the light module, driver and cable attachments every month.

LUMISHORE lights require simple cleaning. Lights should be checked often to ensure the light body and lens area are free from sea growth. In the event that your light requires cleaning, we recommend the use of a soft cloth or soft bristled brush. The glass should be kept clean with a plastic scraper or soft brush. Regular cleaning of the lens will ensure that the light module delivers maximum optical output. DO NOT use an abrasive cloth or cleaning agent as permanent damage to the lens may occur.

DO NOT use any abrasive cleaning materials as these may damage the body of the light.
DO NOT use any cleaning fluids that contain solvents, acids or alkalis.
DO NOT clean using pressure washing or sandblasting equipment.

Slight discolouration of body may occur over life. This does not affect performance, and is not subject to warranty.

Due to nature and high build quality it may on rare occasions be possible to see small levels of condensation, this is normal for high power LEDs and will disappear after cooling and does not harm operation in any way.

No chemicals, cleaners, chemical sprays or sandblasting should ever be applied / used on lights — this will negate warranty

To prolong device lifetime and prevent marine growth build up, a good quality anti-fouling system must be used to coat the external body of the device. This should be renewed regularly.

If lights are covered for any reason e.g. Maintenance or Painting. DO NOT switch the lights on until the covers are removed

Product Support

If you have questions or comments, please e-mail info@lumishore.com or call -
USA (941) 405-3302 or United Kingdom +44(0)1792 398500

Warranty

LUMISHORE Ltd warrants its lighting systems and associated lights and accessories to be free from defects in workmanship for a period of three years, starting from the date of original purchase. Should your lighting system have a problem during this period, please contact your dealer, boat manufacturer or broker as soon as you become aware of the defect.

Misuse, abuse, improper installation, neglect, improper shipping, damage caused by disasters (e.g. fire, flood, storm and lightning), installation by unqualified personnel, unauthorized repair or modification or non-approved installations will void this warranty. For the avoidance of confusion and doubt, non compliance with all installation guidelines, maintenance and operating instructions in this document constitute non conformance with warranty terms.

Full warranty details including exclusions are available at -

www.lumishore.com

Troubleshooting

In the event of one or more of the lights not lighting up then check the LED status on the driver (at the back of the light). The LED will either be continually ON (healthy), OFF (no power to driver) or flashing. Please refer to the table below for what the number of flashes means and what action to take.

LED Status	Meaning	Action to take / Things to check
No LED light on driver	No power to driver	Check fuse / breaker Check connections Check voltage at input to driver connections
Solid LED	Power On	Driver is receiving voltage and operating properly Check the switch is operating correctly
Flashing 2 times	Low input voltage to driver	Check power connections or battery voltage
Flashing 3 times	Light temp too high	Could happen when light is out of water or next to exhaust
Flashing 4 times	Driver temp too high	Driver is mounted too close to an engine or exhaust
Flashing 7 times	LED array voltage out of range	Check the connections between light and driver Check light in each colour to determine if all colours are working
Flashing 8 times	Light not detected	Light is not connected or cable is cut or pinched Light has been connected incorrectly to the driver
Continuous rapid flashing	Driver program corrupt	Reset driver by switching off power for 1 minute, and then switching on again Contact LUMISHORE if problem persists

In the event of an issue, record the serial number(s) of the light(s) and contact your local dealer.



If a light does not switch on, or function normally, it should be disconnected from the power source

Thank you!
For purchasing LUMISHORE lights

TIX404 Light Unit

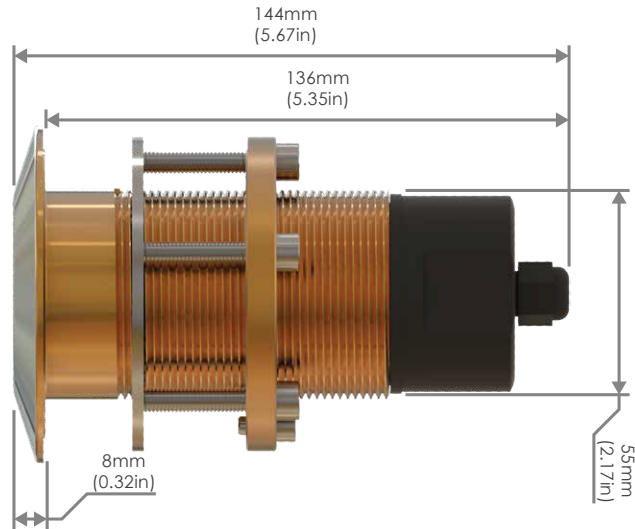
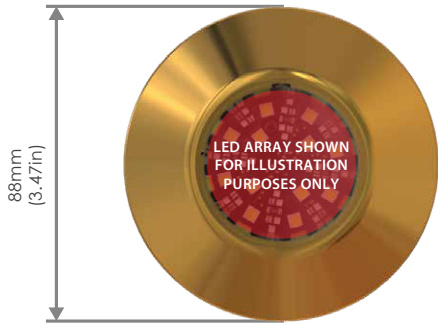

EOS i-Connect Hub

