

TIX404-ORA-WHITE

Single Color Interchangeable Thru-Hull

10 - 31 VOLT
IP-68

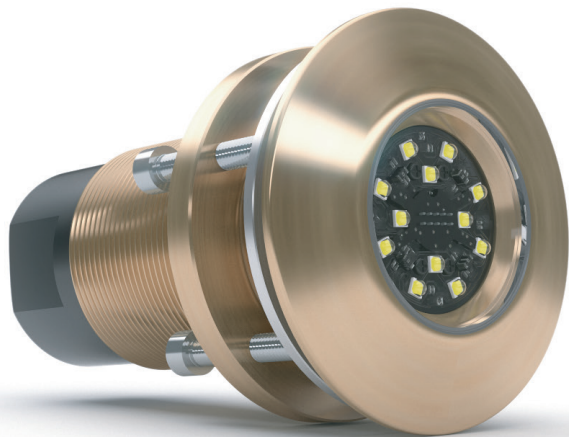

Single Color Interchangeable Thru-Hull Underwater Light

INSTALLATION AND OPERATION INSTRUCTIONS

Congratulations! You have purchased a LUMISHORE advanced LED technology underwater lighting system. Every care has been taken to ensure your compact TIX 404 LED lights arrives in perfect condition, so please enjoy the ultimate experience in underwater lighting.

Please read the following pages to ensure a complete understanding of the LUMISHORE LED lighting system before installation.

Before you Start

- Always ensure that the vessel's power source and battery are disconnected or isolated prior to installation
- A qualified professional should carry out both the electrical and mechanical installation.
- For best underwater illumination, LUMISHORE recommends installation 4" to 12" (100-300mm) below the minimum load water line.
- Choose a location - The light must be mounted on a flat (not curved) surface. For underwater installs mount on transom or side hull only.
- A hole will be drilled to allow the light to be inserted; care must be taken to ensure there is unrestricted access inside the hull.
- When installing three or more lights, equal spacing 2.5'- 3' is recommended to give a consistent light pool.
- The light is temperature sensitive and must not be located close to the exhaust outlet or other heat source.
- Each light should be individually fused 12VDC - 6A, or 24VDC - 4A fuse.
- For Metal Hull or Carbon Fibre installations an Isolation Kit (60-0210) will be required.

LUMISHORE



Mechanical Installation

Tools: Drill, drill bits, marine sealant (Use 3M 4200 (recommended) or similar), 5mm Allen wrench, rags for clean-up:

Hole Cut Out - 57 mm (2.25") - With isolation Kit - 64mm (2.5")

1. Measure the position of the lights on a flat part of the hull. Mark carefully, and double-check for internal obstacles.
2. Drill a perpendicular hole through the hull using an appropriate cutter for the hull material. The hole should be the size given above.
3. The exposed inner hull surface must be properly sealed to prevent water intrusion into the hull before the Thru-Hull is secured in place.
4. Before inserting the Thru-Hull light ensure that the hull surface is free from dirt and grease and remove any existing anti-foul from the hull surface

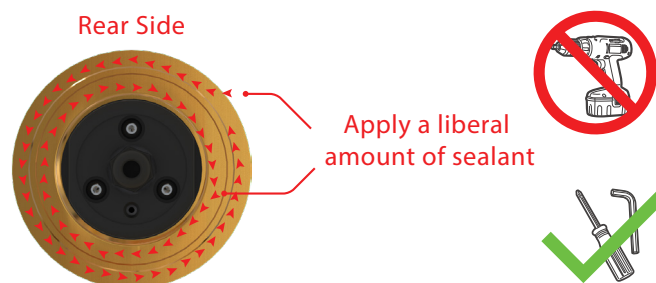

5. Remove the washer and nut from the shaft of the light. Using an approved adhesive (3M 4200 Marine (recommended) or similar). Apply a liberal amount of sealant in a continuous bead around the entire circumference of the sealant groove, and on the base of the stem and on the shaft of the Thru-Hull.
6. Feed the cable through the hole in the hull avoiding any strain on the cable. Gently insert the stem of the Thru-Hull light assembly through the hole in the hull.
7. Apply even pressure with a slight circular motion until the Thru-Hull is flush with the hull surface.
8. From inside the vessel, feed the supplied washer down the shaft of the Thru-Hull fitting. Screw the locking nut in place and tighten the retaining bolts so that they are hand tight (less than 1Nm) - **Do not tighten fully at this stage, excess pressure will push all of the sealant out.**
9. Remove excess sealant that is squeezed from behind the light with a rag. Use a damp cloth to wipe off excess sealant that has squeezed out around the light. DO NOT use chemical cleaners or solvents.
10. Allow the sealant to cure according to the sealant manufacturer's instructions. Once fully cured, using a 5mm Allen wrench, re-tighten each retaining bolt (force less than 3Nm). **Care should be taken not to exceed this force as damage to the light module or hull of the vessel may occur.**
11. Attach the vessel's bonding protection to the bonding bolt on the locking ring.

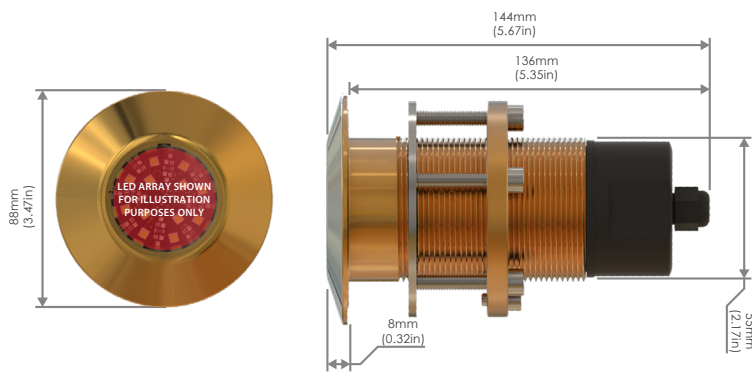

Cleaning and Maintenance

LUMISHORE lights require simple cleaning. Lights should be checked often to ensure the light body and lens area are free from sea growth. In the event that your light requires cleaning, we recommend the use of a soft cloth or soft bristled brush.

- DO NOT use any abrasive cleaning materials as these may damage the body of the light.
- DO NOT use any cleaning fluids that contain solvents, acids or alkalis.
- DO NOT clean using pressure washing or sandblasting equipment.

Slight discolouration of body may occur over life. This does not affect performance, and is not subject to warranty.

Due to nature and high build quality it may on rare occasions be possible to see small levels of condensation, this is normal for high power LEDs and will disappear after cooling and does not harm operation in any way.

If the lights are covered for any reason, e.g maintenance, or painting DO NOT switch the lights on until the covers are removed.

Electrical Installation

Plan the cable route prior to installation. Ensure all cables are correctly rated. Each light must be individually fused. The cable connections are:

Red 12V or 24V DC
Black Ground

The fuse ratings are:

12V DC	6A
24V DC	4A

The lights have a simple ON / OFF operation, and will come on in either White, or Blue depending on the model.

All connections must be made waterproof.

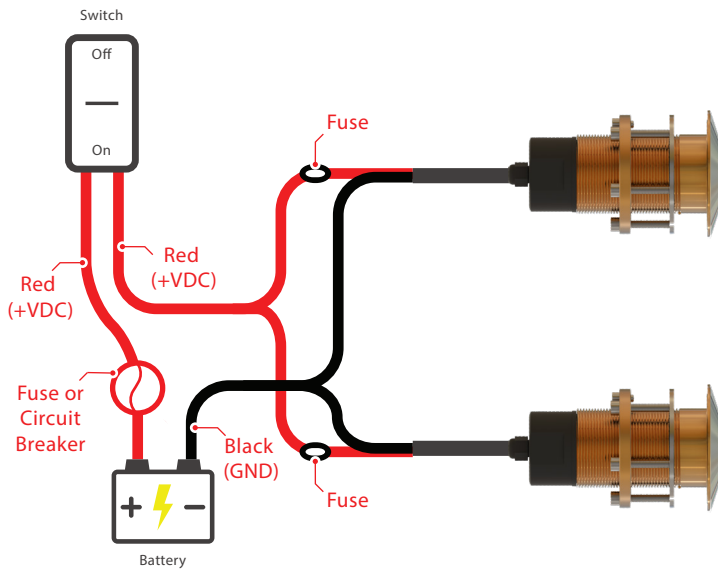

The light cables can be extended. Ensure the correct cable gauge is used to avoid issues with voltage drop. Follow ABYC recommendations for no more than 3% voltage drop. Consult a qualified electrical installer, or contact Lumishore for further information.

Make sure the lights are tested, and working as expected before the boat goes back in the water.

Warranty

LUMISHORE Ltd warrants the TIX 404 to be free from defects in workmanship and materials for a period of three years, starting from the date of original purchase. Misuse, abuse, improper installation, neglect, improper shipping, damage caused by disasters such as fire, flood, and lightning, installation by unqualified personnel, unauthorized repair or modification will void this warranty. For the avoidance of confusion and doubt, non-compliance with all installation, maintenance and operating instructions in this document constitute non-conformance with warranty terms.