

eclipse Command Center installation manual

Please read the following pages before attempting installation.

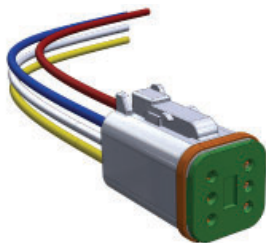

PARTS INCLUDED



3 x ECLIPSE cable harness



1 x FIELD INSTALL RJ45 IP67 COVER KIT

ECLIPSE Command Center Installation Instructions

Before you start...

- Always ensure that the vessel's power source and battery are disconnected or isolated prior to installation.
- A qualified professional should carry out both the electrical and mechanical installation.
- The ECLIPSE Command Center must be mounted in a dry location and on a flat (not curved) surface away from any sources of heat or vibration
- The ECLIPSE Command Center works via its inbuilt Wi-Fi with a smart device such as a phone/tablet. It is also compatible with multi-function displays (MFD). - check the compatibility of your MFD prior to installing the ECLIPSE Command Center. The MFD may require a software update.
- The ECLIPSE Command Center has an accessible SD card slot for future software upgrades. When mounting, future access to this SD card slot should be taken into consideration.
- The ECLIPSE Command Center is designed to work with **12V boats only**. It can operate between 10 - 15Volts DC. Do not connect to voltages outside of this range or connect directly to AC voltage.
- Ensure the ECLIPSE command center is connected to a circuit breaker or suitable fuse. The total max load for the command center is 30amps (10amps per zone), **But for further connection / zone limitations please consult the manual for the type of light you are connecting**. The Power cable selected should be capable of handling the 30amp load with a max 3% voltage drop from battery to Command center.

Connection Options...

The ECLIPSE Command Center is a cross platform device. Via Ethernet, it can connect to a single or multiple MFD network or be controlled with its inbuilt Wi-Fi by a smart Phone/tablet.

Inbuilt Wi-Fi connection



Single MFD connection



Multiple MFD/ device connection



Note: Use an MFD manufacturer specific network expansion port. Consult with your MFD installation guide or contact a dealer for further assistance.

Connecting the ECLIPSE Command Center to an MFD.

Connection to the various brands of MFD's are brand specific. The following diagrams show the components required to connect the ECLIPSE Command Center to each brand.

Lumishore supplies a Field install RJ45 IP67 cover to make your connections to the ECLIPSE Command Center waterproof. The cover should be used on all installations.



Garmin MFD install - Use Garmin conversion cable PN: 60-0372 and Garmin network cable
(Note: The Garmin conversion cable must be installed. Only use Garmin network cables)

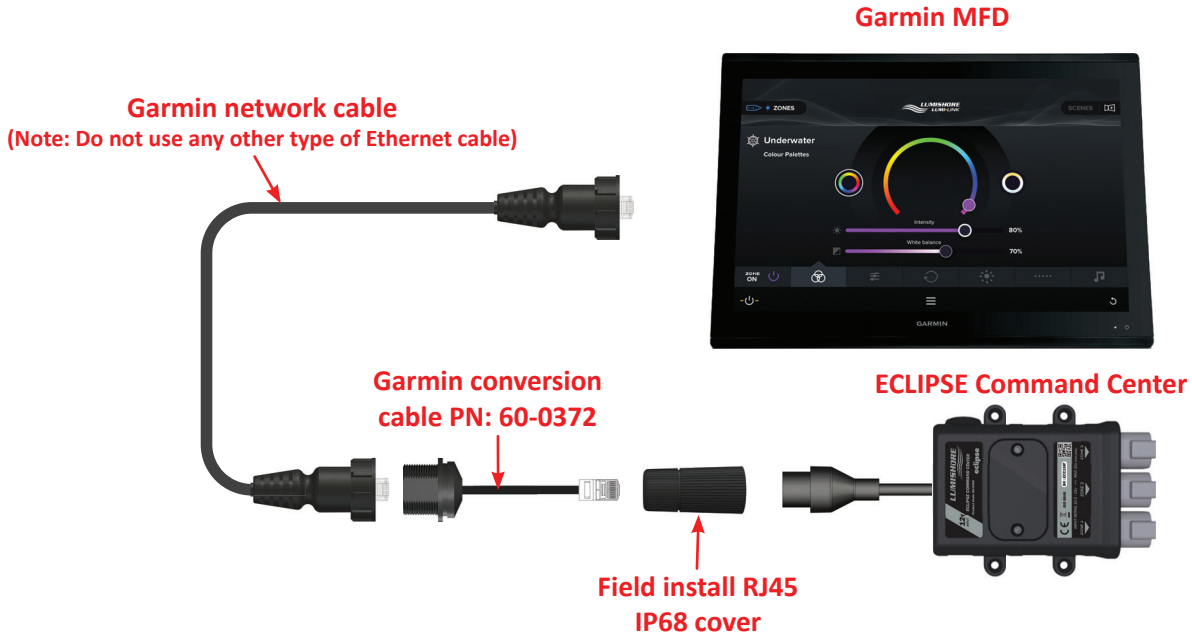

Raymarine MFD install - Use Raynet to RJ45 cable, Raymarine PN: A80151

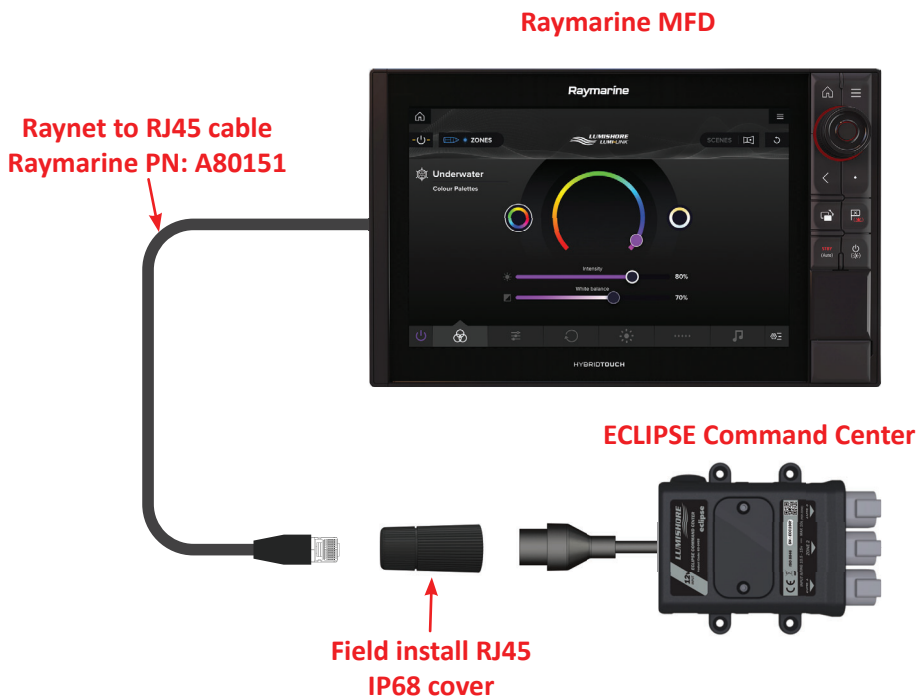

Simrad & B&G MFD install - Use Navico conversion cable PN: 60-0373

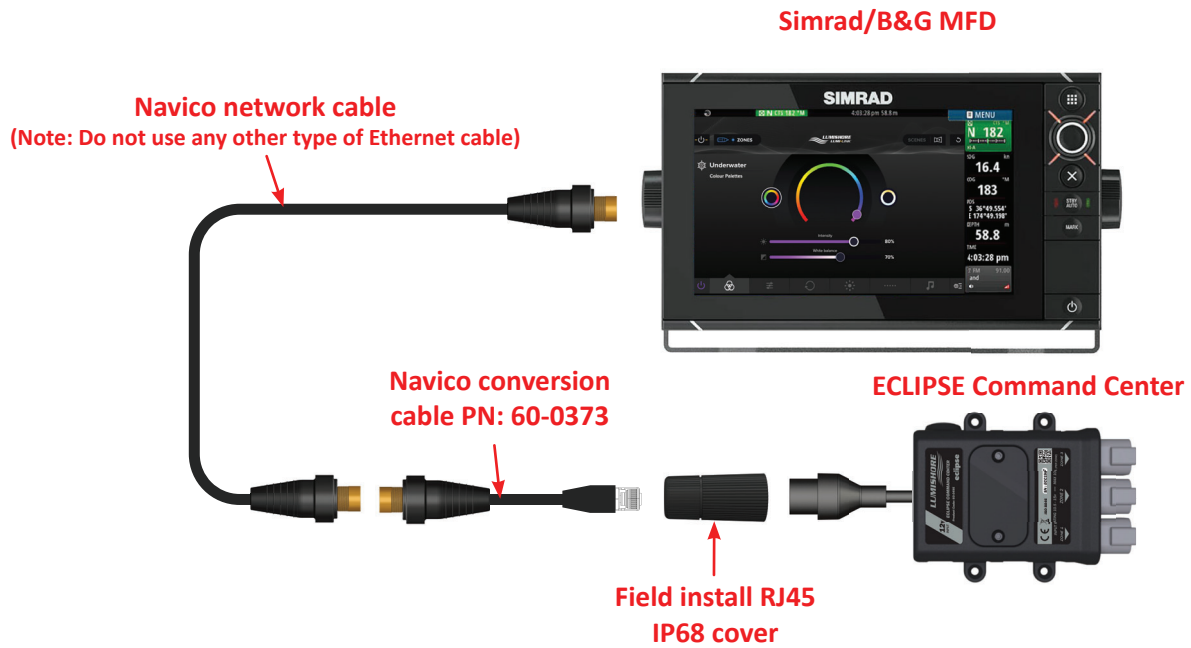

Furuno MFD install - Use standard ethernet CAT5e cable.

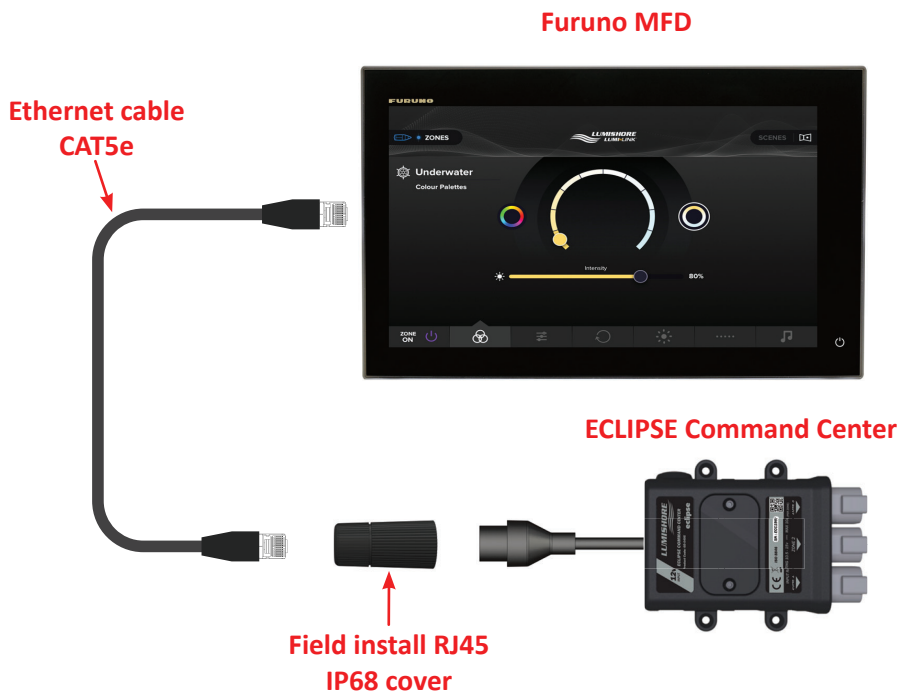

Note: Furuno MFDs require a different SD card to be installed in the ECLIPSE Command Centre (PN: 60-0515). With power switched OFF, unscrew the SD card port cover. Remove the old SD card using tweezers. Fit the Furuno SD Card and replace the port cover.

ECLIPSE Command Center connections

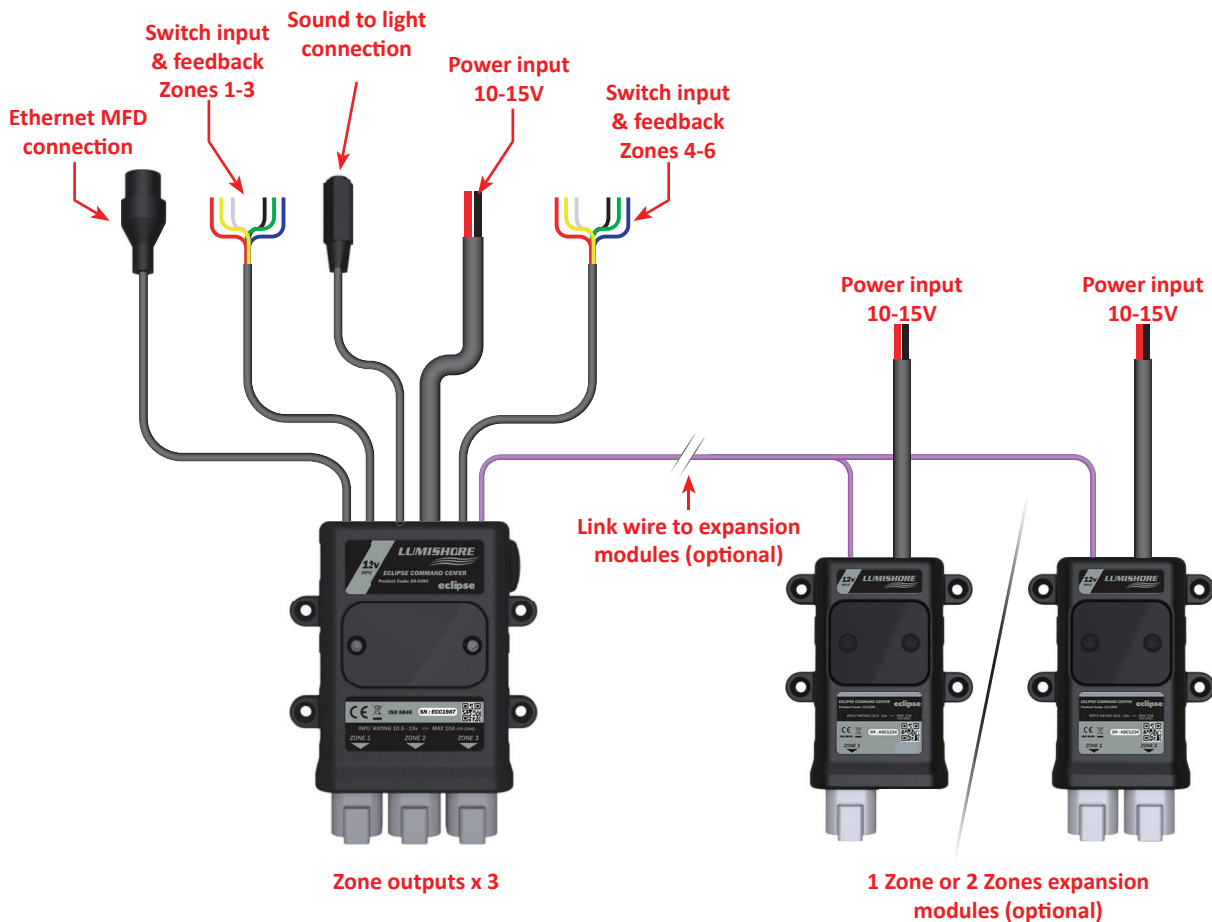

Ethernet MFD Connection

Used to connect to various brands of MFD, see previous section for specific MFD installation.

Power input 10-15V

Ensure the ECLIPSE command center is connected to a circuit breaker or suitable fuse. The total max load for the command center is 30amps (10amps per zone), the Power cable selected should be capable of handling this load with a max 3% voltage drop from battery to command center.

Sound to light (optional)

A 3.5mm Jack socket is included. Use a 'Jack to Jack' cable or a 'Jack to Phono' cable as required to plug the 'Line out' from a stereo or iPad/iPhone.

For best results use a stereo output that has constant output irrespective of volume i.e. when using an iPad or iPhone use the line out rather than the headphone socket. That way the sensitivity of the controller will not need continuous adjustment when changing volume.

NOTE: Sound to light feature works with the RGBW Underwater lights only. Single / Dual color lights do not have sound to light feature built in.

Switch and feedback Zones 1-3 & 4-6 (optional)

Connect a momentary switch to each zone to turn zone on/off. Press and hold the switch to adjust brightness level. The switch feedback can be used with illuminated switches or LED indicators to show the on/off status of the zone. See switch connections diagram on Page 7.

Switch connections

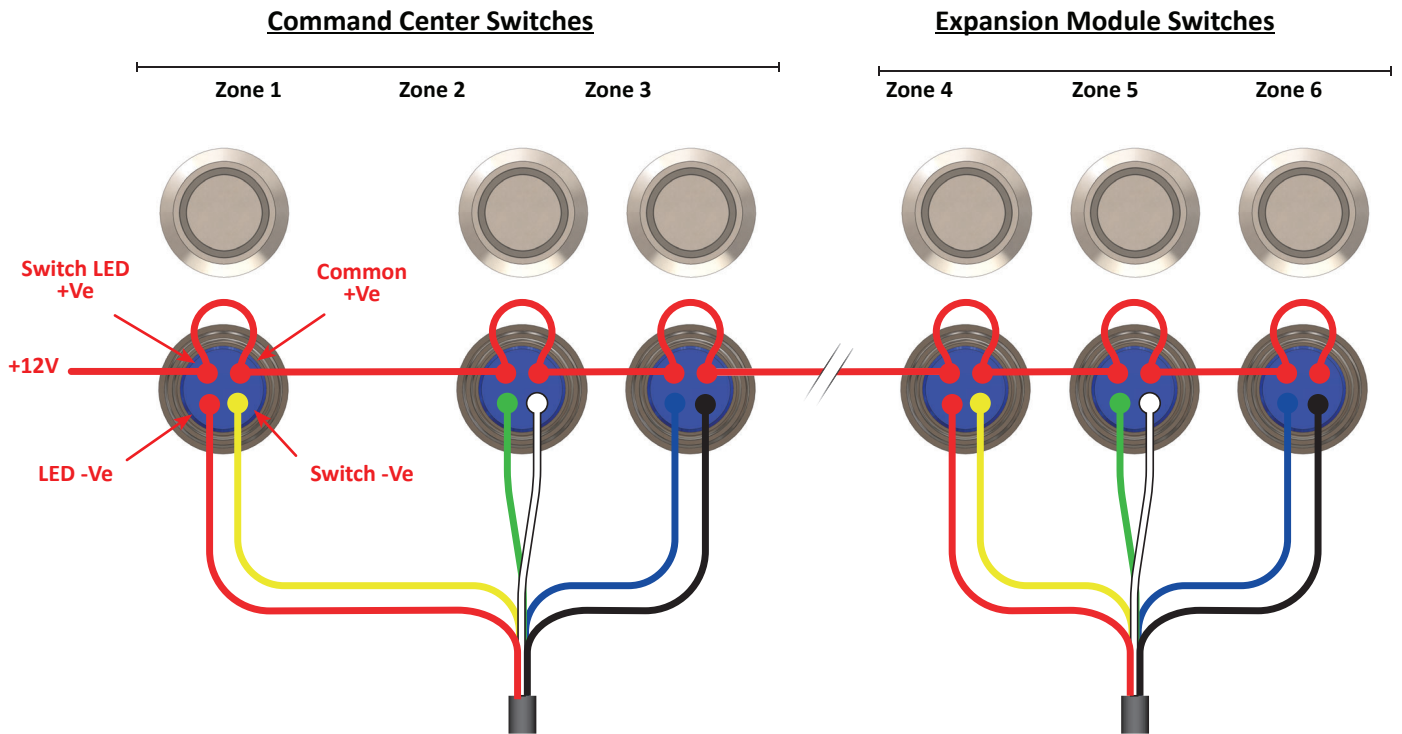

It is important the correct switch connections are used as shown in the connections diagram on Page 6.

Note: Zones 1-3 and Zones 4-6 use different switch input cables from the Command Center.

Connections are as follows;

Zones 1 - 3

Zone	Switch inputs	Switch feedback LED
1	Yellow	Red
2	White	Green
3	Black	Blue

Zones 4 - 6

Zone	Switch inputs	Switch feedback LED
4	Yellow	Red
5	White	Green
6	Black	Blue

Link Wire – connection of expansion modules (single or double)

See ECLIPSE expansion module wiring on Pages 12 for more information.

Zone outputs

Each zone output is multifunctional. It can be configured very simply via the User interface to control ECLIPSE Downlights, Courtesy Lights, Strip Lights, Neon Flex, Flood Lights and Underwater Lights without any additional drivers or modules.

Each zone can be configured to control different types of lights (see example diagram below) but lights of different types cannot be connected to the same zone.

When directly connecting lights to the zone outputs, the max load per zone is 10 amps. For full installation instructions for the type of light you wish to connect please refer to the lights installation instructions. These can be found at www.lumishore.com/resources and search for the product name.

Each zone should be fused with a suitably size blade fuse. The size of fuse will depend on the model of light and the number of lights attached to the zone.

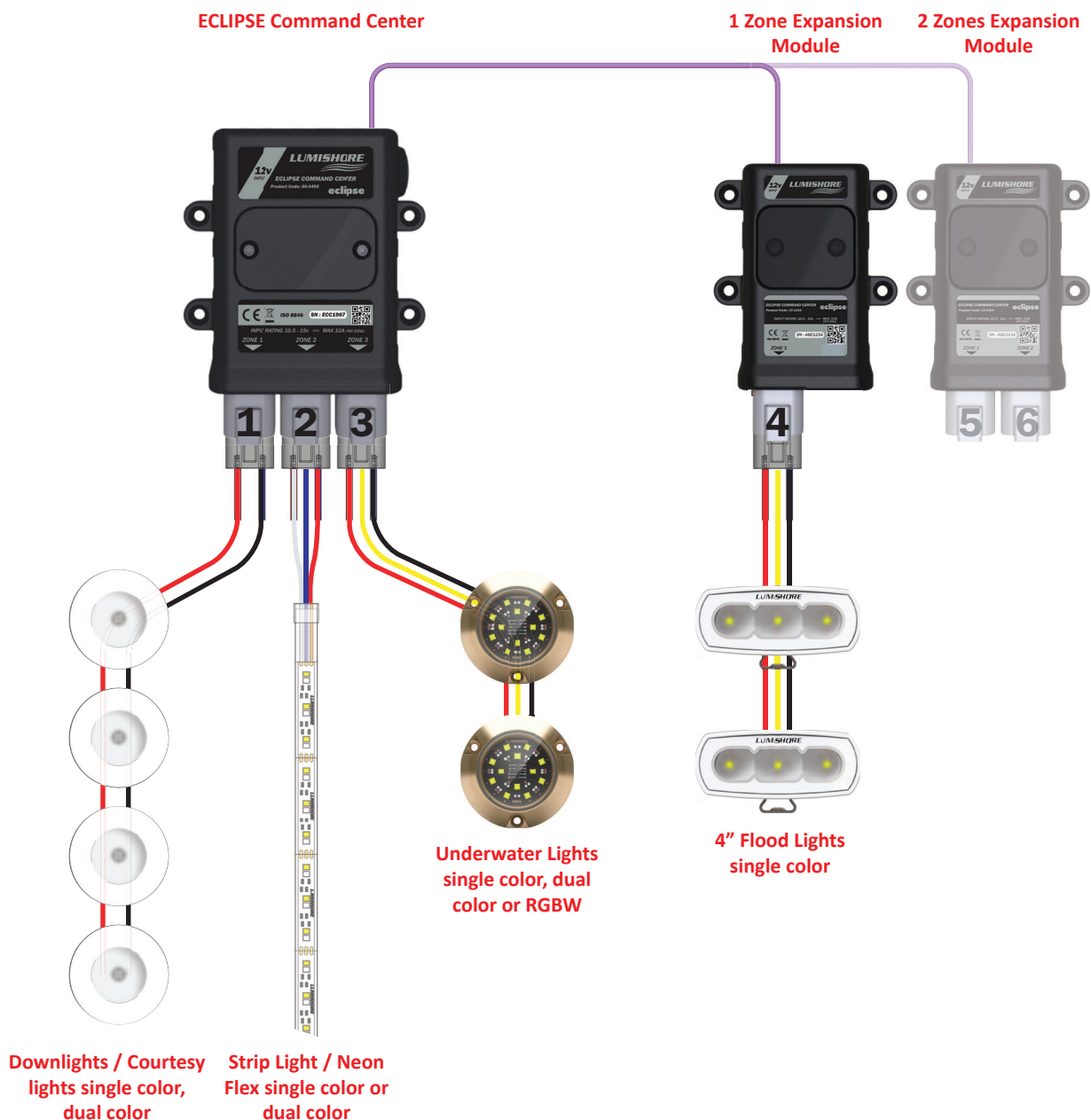

ECLIPSE cable harness wiring

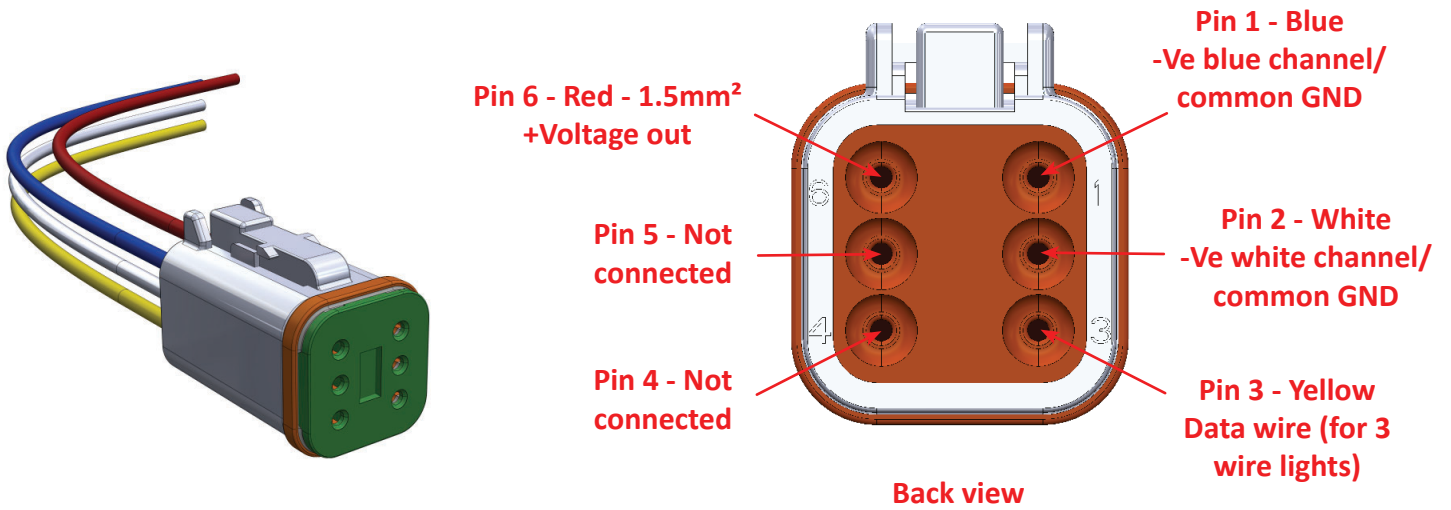

Command Center LED status

In the event of the command center/expansion modules not functioning properly check the LED status beneath the fuse window. The LED's will either be continually ON (healthy), OFF (no power) or flashing. See status LED sequence below.

Note: The removal of the fuse window may be required to help identify the correct status. To fully understand the LED status please refer to the tables below.

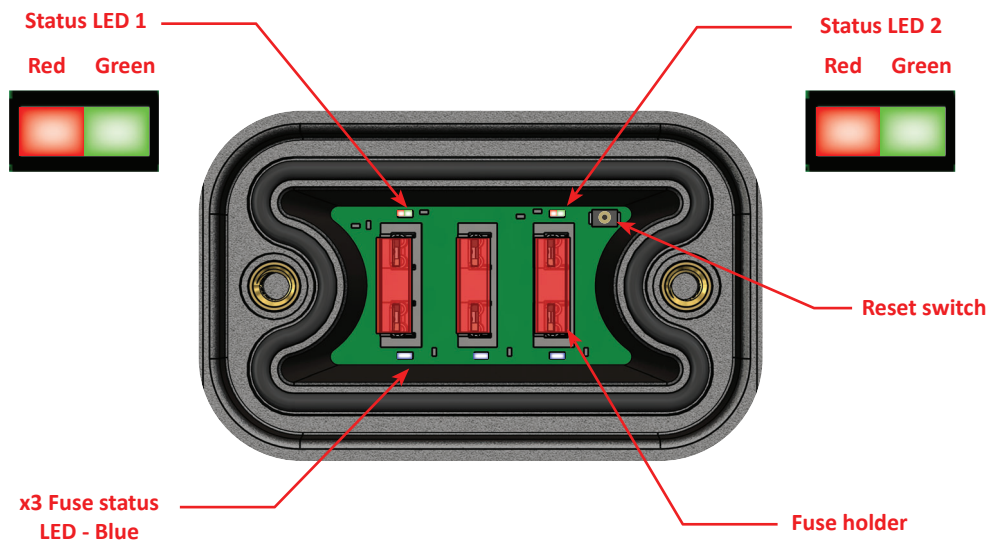

Status LED 1

- Red (solid) / Green (solid) = System ready, network OK



- Red (solid) / Green (flash) = System ready, no network detected

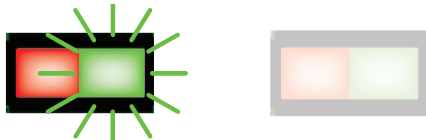

- Red (solid) / Green (quick flash) = Firmware update in progress



Status LED 2

- Red (solid) / Green (solid) = Correct input voltage detected



- Red (solid) / Green (off) = Incorrect voltage detected



Fuse status LED x3

- Blue (solid) = Zone fuse OK



- Off = No fuse



Once the status has been identified ensure the fuse window is secured correctly to ensure IP68 rating. Check that the O-ring is seated properly and does not get pinched when re attaching window. Water leaks due to incorrect installation of fuse window will not be covered under warranty.

Reset switch

The reset switch is available to reset network settings or to return the Command Center back to its factory default settings. Use a small pin or similar to press and hold the switch.

- Press, hold for 10 seconds, release = Reset Wi-Fi settings (SSID, password and turns internal Wi-Fi On)
- Press, hold for 30 seconds, release = Full factory reset (All of the above and clears any user Zones and scenes)

Expansion module wiring

Zone toggle switch

Use the zone toggle switch to set the zone number of the expansion module to either zone 4 or zone 5. The status led will change colour to indicate the zone number RED = zone 4, Green = Zone 5

Expansion module LED status

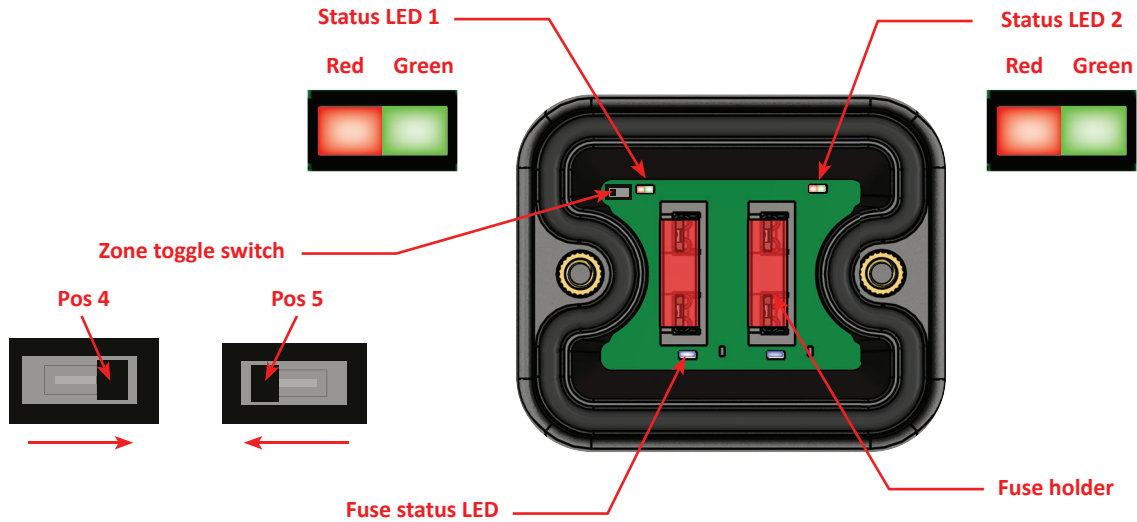

Status LED 1

- Green (solid) = Expansion module set to Zone 4 - link On



Status LED 2

- Red (solid) = Expansion module set to Zone 5 - link On



- Red (flash) or Green (flash) = No link detected

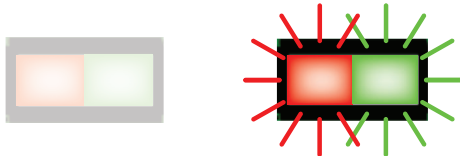

Fuse status LED

- Blue (solid) = Zone fuse OK

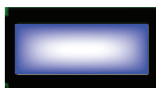

- Off = No fuse



Correct installation examples - Up to 6 zones

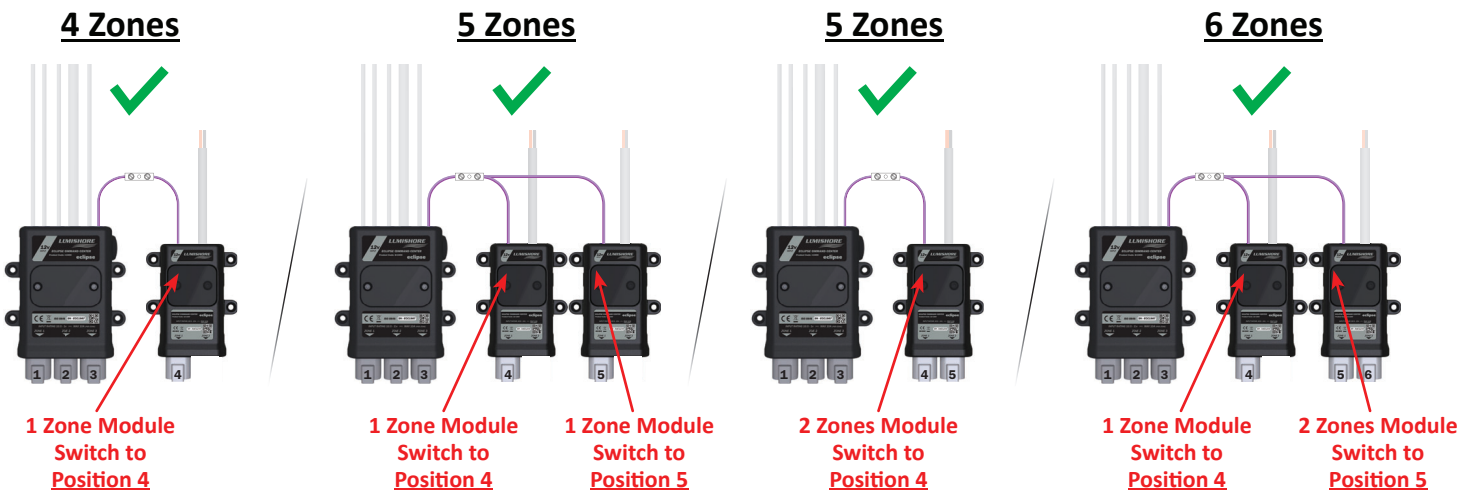

Incorrect installation examples - up to 6 zones

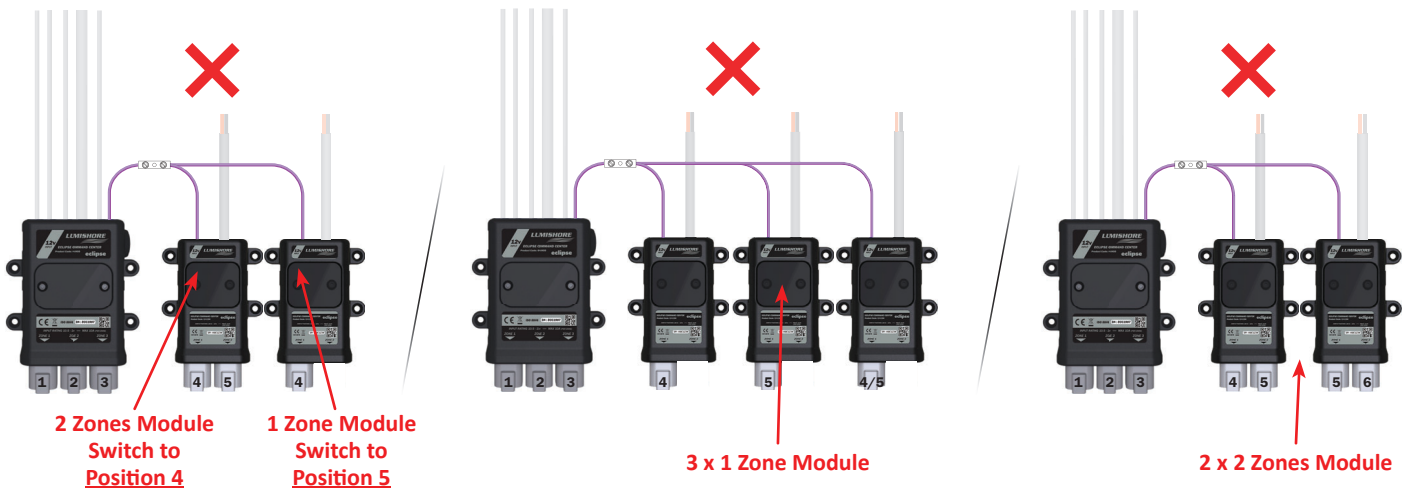

Warranty

LUMISHORE Ltd warrants its lighting systems and associated lights and accessories to be free from defects in workmanship for a period of three years, starting from the date of original purchase. Should your lighting system have a problem during this period, please contact your dealer, boat manufacturer or broker as soon as you become aware of the defect.

Misuse, abuse, improper installation, neglect, improper shipping, damage caused by disasters (e.g. fire, flood, storm and lightning), installation by unqualified personnel, unauthorized repair or modification or non-approved installations will void this warranty. For the avoidance of confusion and doubt, non compliance with all installation guidelines, maintenance and operating instructions in this document constitute non conformance with warranty terms.

Full warranty details including exclusions are available at www.Lumishore.com.