

LUX Courtesy Light CL25 Installation Guide

Full spectrum color tunable lighting, including cold and warm white light

Please read the following pages before attempting installation

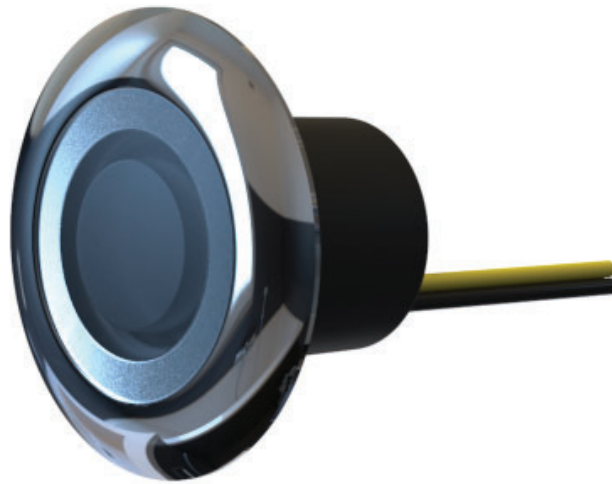

Before you start...

- Always ensure that the vessel's power source and battery are disconnected or isolated prior to installation.
- A qualified professional should carry out both the electrical and mechanical installation.
- The Lux Courtesy Light Is designed to be used in conjunction with the Lumishore Lux Light Module (see diagram below). Do not connect to any other 3rd party lighting control products or dimmers.
- The lux Courtesy Light is fully sealed and can be installed inside or outside, it can be installed in wet areas but is not designed to be permanently submerged in water.
- Choose a location – the light must be mounted on a flat – not curved surface.

Basic Dimensions:

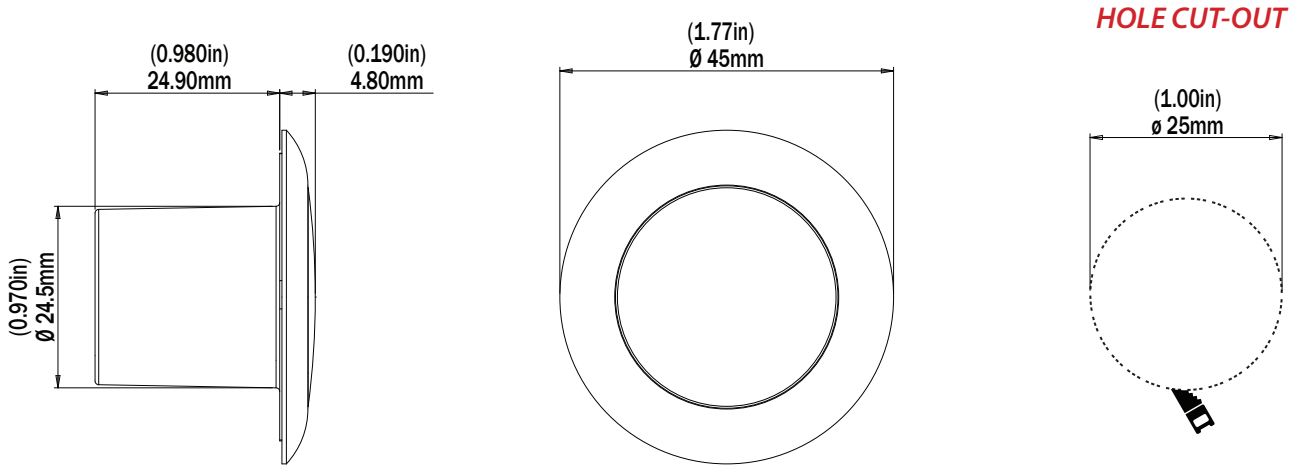

Installation Diagram



NOTE: The Lumishore Lux Courtesy Light CL25 requires connection to the Lumishore Lux Light Module. For full electrical installation and wiring diagrams please refer to the Lux Light Module installation guide.

Power rating = 0.5watts per light

Typical current draw = 0.06A @ 12Volt / 0.03A @24Volt

Mechanical Installation:

Using a hole saw cut a 1in hole, always cut the hole smaller than needed and file to the correct size to ensure a snug fit. Screw the body in place using suitable countersink screws, fit lens and stainless steel bezel as shown below. Ensure both O-Rings are in place before fitting.

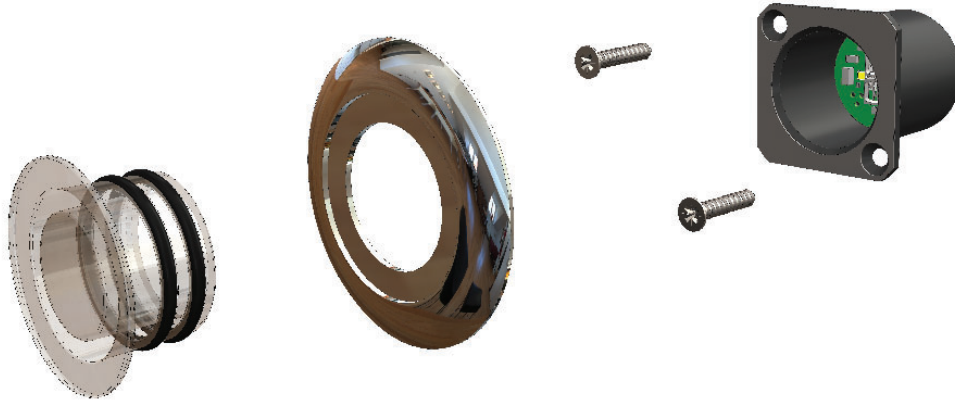

CLEAR marine sealant should be used between lens and bezel and behind the bezel (see below), ensure no sealant contacts O-rings. Fit lens and O-rings through the bezel and clean any excess adhesive using a soft cloth and soap and water - **DO NOT USE CHEMICAL CLEANERS.**

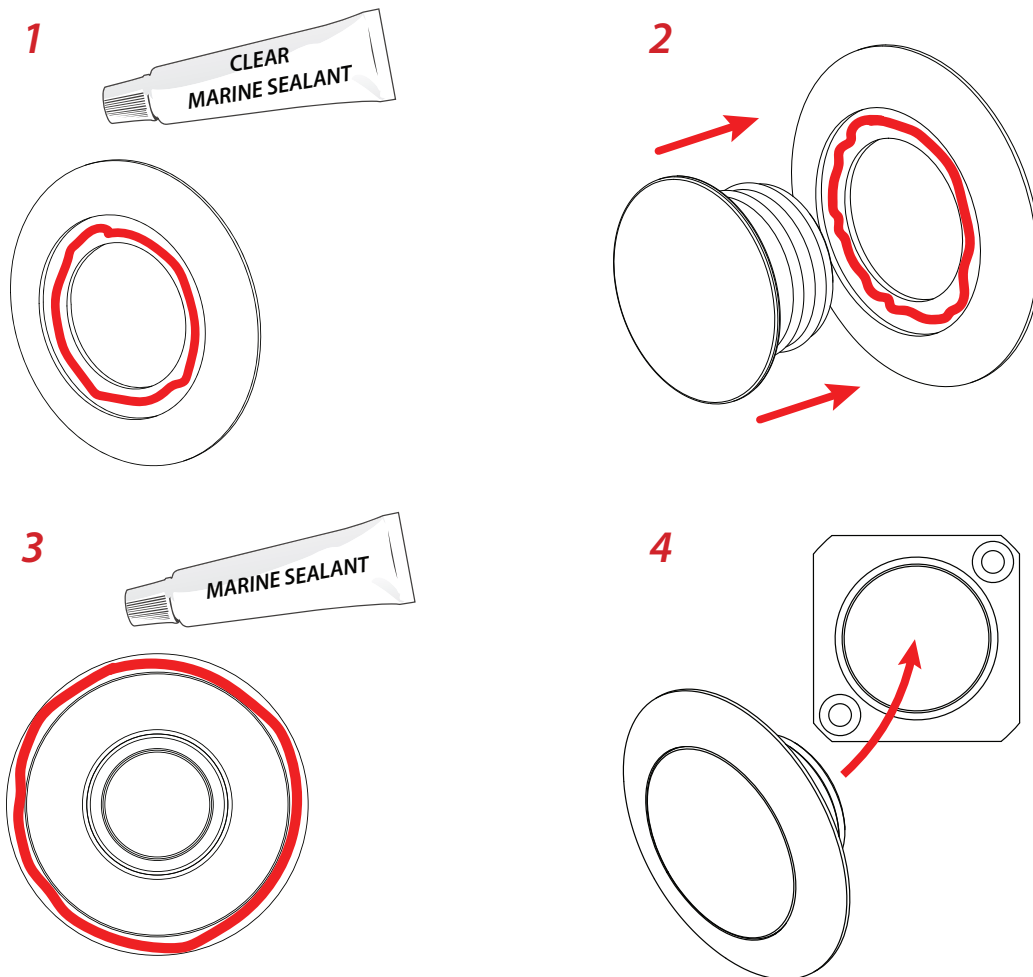

For exterior installations or wet areas it's also recommended that the light body is fixed in place using a suitable marine sealant. Push into place using a slight rotation of the light to spread the adhesive evenly. Clean any excess adhesive using a soft cloth and soap and water – **DO NOT USE CHEMICAL CLEANERS.**

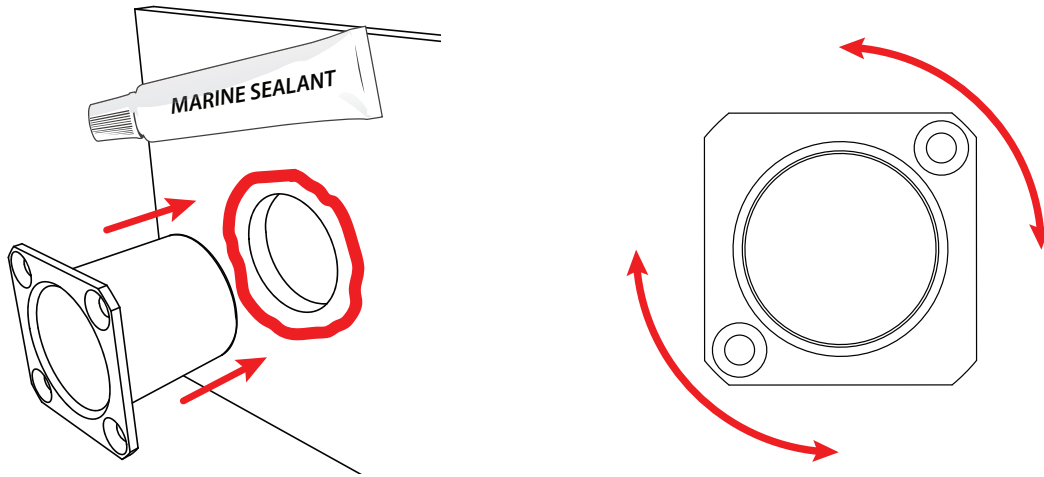

LUMISHORE



Warranty

LUMISHORE Ltd warrants its lighting systems and associated lights and accessories to be free from defects in workmanship for a period of three years, starting from the date of original purchase. Should your lighting system have a problem during this period, please contact your dealer, boat manufacturer or broker as soon as you become aware of the defect.

Misuse, abuse, improper installation, neglect, improper shipping, damage caused by disasters (e.g. fire, flood, storm and lightning), installation by unqualified personnel, unauthorized repair or modification or non-approved installations will void this warranty. For the avoidance of confusion and doubt, non compliance with all installation guidelines, maintenance and operating instructions in this document constitute non conformance with warranty terms.

Full warranty details including exclusions are available at www.Lumishore.com.

The LUX Light Control Module is designed to work with Lumishore LUX lighting products ONLY, do not use with other light brands, this will invalidate the warranty.